



Transforming the Flowsheet for Tailings

Innovation for a Sustainable Future

Presenters:

Andrew Vietti

Campbell Haines

Matt Pyle

Hosts:

Philip Bangerter

Laurie Reemeyer

Sponsors & Mission

Premier



Corporate



To Accelerate the Adoption of Eco-Efficient Minerals and Metals Production Practices

Celebrate. Collaborate. Communicate.



Cross-sector Collaboration

ACTIVITIES



CEEC Medals



Resource Centre



Workshops



Case Studies

INITIATIVES

Energy Curves

Global Water Initiative (GWI)

Global Tailings Initiative (GTI)

Mining Specific Readiness Level



Agenda

- Welcome, objectives, housekeeping
- Game set-up
- Classifying tailings
- Process design options
- Storage, closure and landforms
- Conclusions
- Call to action



Participant from the CEEC International Water In Mineral Processing Workshop – Santiago, August 2025



Disclaimer

This workshop brings together invited participants based on their technical expertise and leadership in areas such as comminution, process innovation, sustainability, and operations strategy.

- **Chatham House Rule** applies: Participants are free to use the information discussed, but the identity or affiliation of speakers or contributors will not be disclosed.
- Views and comments shared during the workshop are personal and do not necessarily reflect the views of their respective organisations.
- **Please respect all contributors** – every perspective is valuable. We aim to foster open, respectful dialogue for the benefit of the wider industry.
- The discussion, conclusions and outcomes of this workshop will be used to produce a final industry-facing report, which will be peer reviewed and **may be published in a non-attributive format** following CEEC quality standards and operational procedures.



Global Tailings Initiative (GTI)



- CEEC's GTI will help industry build towards responsible, low-impact tailings practices by collaboration activities
- Initial work is focussed on the ore characteristics and upstream processing and the choices that affect tailings properties
- GTI will include expert working groups, case studies, workshops, and knowledge-sharing outputs.



1

Introduction and Workshop Outline

Philip Bangerter,
Laurie Reemeyer



Introduction

- Introductions to the team
- Why are we here
- What we hope to discuss
- What we hope you get out of it
- Overarching hypothesis for improving tailings outcomes
- Interactive tailings game
- What we don't plan on getting into.



Presenters & Hosts (10+ years ago)



Andrew Vietti
Director
Vietti Slurrytec



Laurie Reemeyer
Principal Consultant
Resourceful Paths



Matt Pyle
Chief Technical Officer
Ausenco



Philip Bangerter
Independent Consultant
Director, CEEC International



Campbell Haines
Technical Consultant,
Comminution
Ausenco



Why we are here

Grow a network of like-minded inter-disciplinary tailings practitioners

Discuss ideas/examples/opportunities that perhaps the industry has not fully explored

Share knowledge, information, and test the appetite for change in tailings management



Overarching Hypotheses



Changing drivers for decision making;

Increased risks and costs for conventional TSFs, as ore grades decline & facilities get larger

Prevalence of clay and fine-grained minerals in orebodies & water sources

Emerging process practices, technology & flowsheets



Relatively little research or industry-wide understanding of the factors that actually drive tailings dewatering and storage strategies

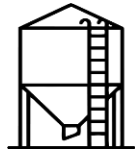

There are industry siloes that inhibit best outcomes



Outcomes improve when disciplines reach a 30% level of knowledge in each others expertise



What we hope you will get out of it



Make connections to like-minded professionals interested in better tailings outcomes



Discover ideas worth pursuing



Have your interest sparked about a wider Tailings COP



2

Context

Campbell Haines



Some context....

- From 2019 to 2023
 - 20+ tailings dam failures in Brazil, India, China, Australia, Canada, Boliva, South Africa, Tanzania, Peru, Mexico, Angola, Turkey
 - More than 25 Mm³ of tailings and water released
 - 400+ people killed
 - Significant damage to community infrastructure and resources
 - Major environmental damage
- Recent major tailings dam failures at Samarco and Brumadinho has focussed world attention on the 100+ year history of poor performance of tailings dams



Brumadinho Dam Failure in Brazil



Not a good story...

Over the last 65 years;

- TSFs continue to fail at the same rate (roughly 5 per year)
- Failures are more severe (off-site rather than localised)
- Release volumes are increasing
- Failures from weather and drainage deficiencies (water) are increasing
- Steady rate of fatalities

Data from Rana et. al. (2022) – Global magnitude-frequency statistics of the failures and impacts of large water-retention dams and mine tailings impoundments.

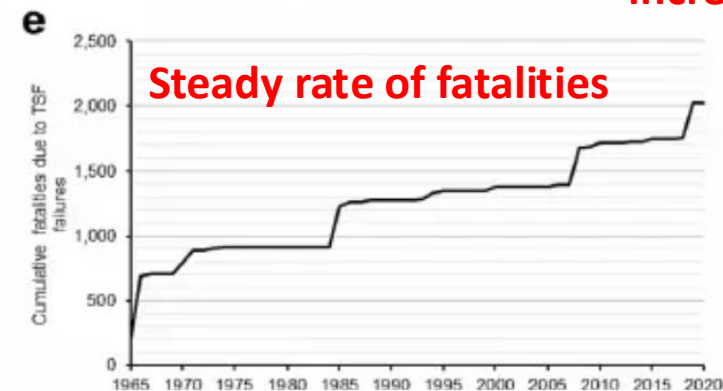
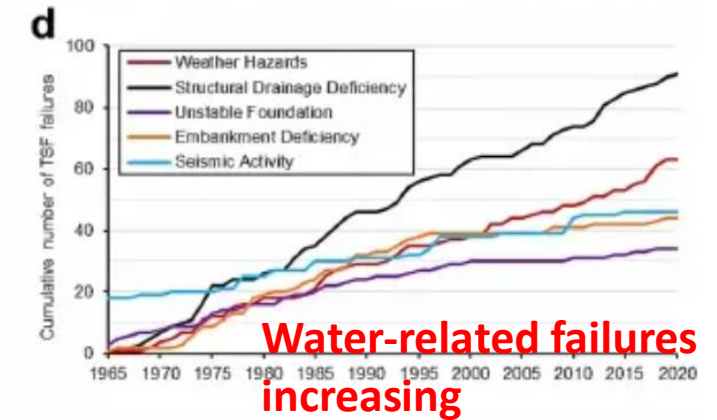
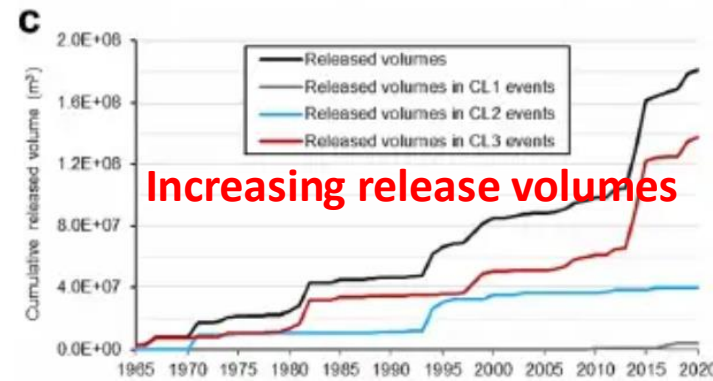
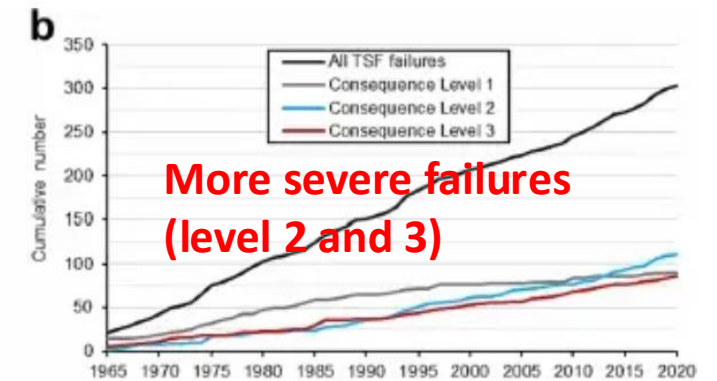
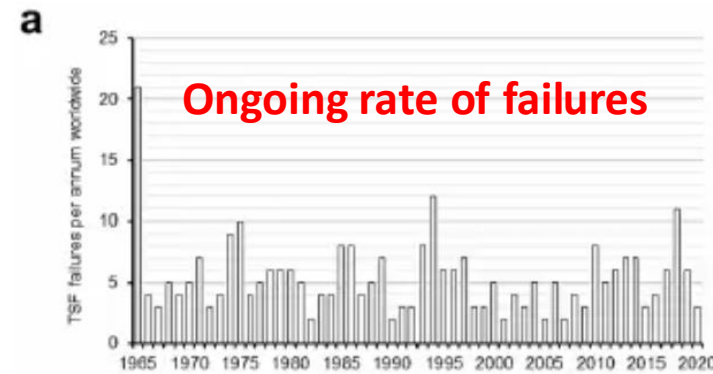

What does it mean for the industry?

- Stakeholders have had enough – Regulators, Communities, Investors
- TSF wall raises now take between 5 – 10 years to permit. New TSFs toward upper end of that range. Upstream raises are increasingly outlawed.
- Operators are genuinely facing the threat of shutting down due to no tailings space
- Several projects and studies underway to remove material from tailings dams and generate extra capacity
- Industry Guidelines and QA practices are more onerous than ever...but still the failures occur – Why?



Why do dams fail?

Key factors are

1. Water content in the dam
2. Dam wall construction method (upstream vs downstream)
3. Management

How are we combating these factors?

- Upstream dams are now illegal in many (but not all) jurisdictions or prohibited through company policies
- Increased management and QA practices are in place;
 - Australian Government Leading Practice Guidelines
 - ANCOLD/CDA Guidelines
 - Global Tailings Review – GISTM
 - MAC steadily rolling out TSM, endorsed by MCA
 - Mining Company internal standards e.g., Rio Tinto D5
 - ICOLD Bulletin 194 Tailings Dam Safety
 - SME Tailings Management Handbook
 - Independent Tailings Review Boards (ITRB)
- But we are yet to see progress in reducing water content in dams. Most sites don't even know how much water is in their dams.



What is the result of our current collective actions?



Project Development Context in 2026

- Demand for commodities continues to increase
- Grades of minerals are reducing
- Economies of scale may have hit their limit
- Brownfield development is the primary source of new forecast production
- Project NPV discounting can underestimate the true whole-of-life cost, particularly as it relates to closure and mine life extension. *Is it common or correct to discount future liabilities [costs] at the same rate as revenue?*
- Water is a source of tension for **all** projects, regardless of jurisdiction and climate factors
 - Water is often the single biggest source of stakeholder tension during project approval
 - Inadequate water access can limit project scale or return
 - Entrained water within tailings the largest risk to dam failure and largest opportunity – *how do we do more with what we have?*

World Copper Mine Production, 1900-2016

(thousand metric tonnes copper)
Source: ICSG

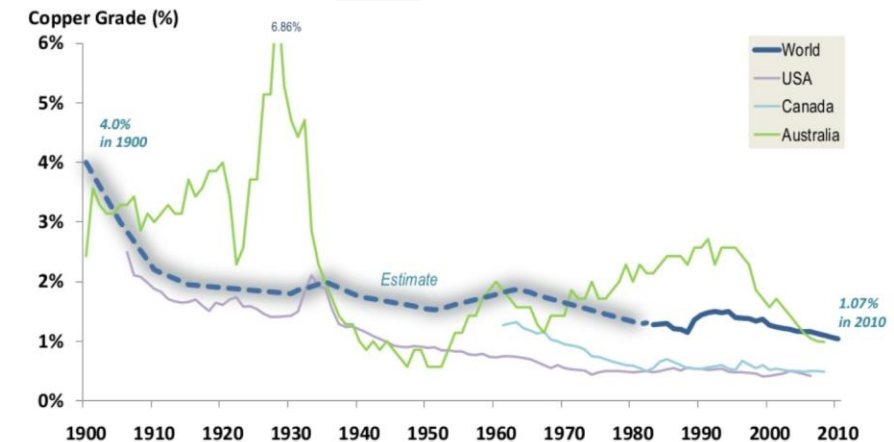
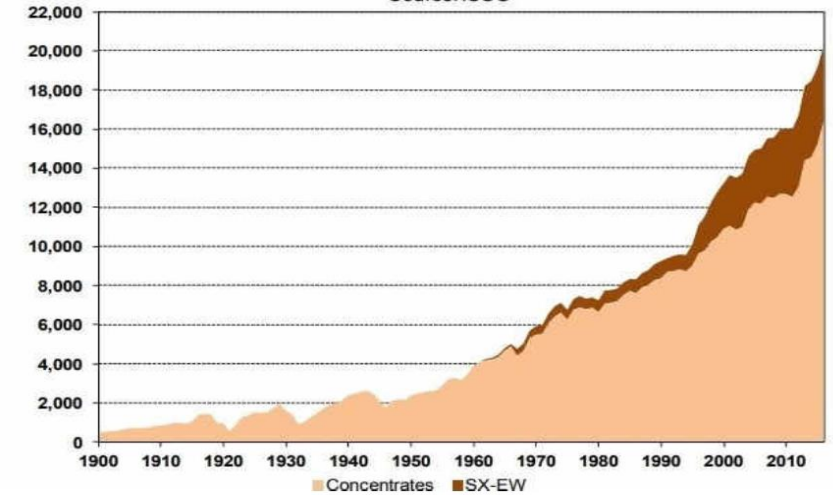

Sources: USGS, Mudd (2009)
Brook Hunt, UBS

Note: Rise in ore grade in Australia from 1972 onwards is due to startup of the high-grade Olympic Dam mine

[AFR: Inside the growing global hunt for Copper](#)



Why not just filter tailings?

- OK for high grade projects, but...
- Low grade projects (which produce most tailings) can't afford a 10 – 25% margin haircut

Commodity	Product Margin (USD) ¹	Head Grade	Margin (\$/t filtered tailings)	Margin Reduction, for additional incremental \$1.50/t tailings (%)
Coal (thermal)	40 \$/t	60%	300	0.5
Zinc	0.35 \$/lb	10%	90	1.7
Gold – high grade	200 \$/oz	8 g/t	51	2.9
Copper – high grade	1 \$/lb	2%	45	3.3
Alumina	50 \$/t	40%	33	4.5
Iron Ore (Magnetite)	20 \$/t	35%	23	6.5
Copper – Low grade	1 \$/lb	0.6%	13	11.5
Gold – Low grade	200 \$/lb	1 g/t	6.4	23.4

1. Margin by commodity, determined as ore value minus C1 costs, based on 90th percentile of operating sites

- Filtered tailings are not the only alternative to conventional tailings!



What tricks are we missing and what is it worth?

- Are we missing the true costs of our current thinking?
 - Water access impacting project scale, particularly after the initial high grade years
 - Water supply costs eroding value (Chile = US\$ 4/m³ sea water)
 - Entrained water driving up embankment factors of safety = higher costs
 - Limiting resource to reserve conversion due to unsustainable later phase cost / permitting requirements.
 - Are we modelling water make up against rate of rise with conventional dams?
- South America, particularly Chile well ahead on tailings dewatering innovation through necessity. Useful reference on current thinking published by Cacciuttolo in Water (2022).
- Dry climates are not the only opportunity areas. Eliminating wet dams in wet areas reduces risk and liabilities (water treatment, factors of safety)
- If water removal from tailings is the key that unlocks capacity in our current and future projects – how well do we understand the mechanisms fundamental to drainage – and are we missing the tricks used in other areas?
Is this the knowledge we need to build in order to innovate?

Tailings Management Technology	Make-up (m ³ of tailings ton)														Legend	
	0.2	0.25	0.3	0.35	0.4	0.45	0.5	0.55	0.6	0.65	0.7	0.75	0.8	TSF Operation		
Filtered Tailings (FTT)	1,2	3,4													1.- Cerro Lindo	2.- El Peñon
Paste Tailings (PTT)					5	6	7	8							3.- Rakito La Coipa	4.- Mantos Verde
Thickened Tailings (TTT)							9	10	11						5.- Chitchorro	6.- Alhue
Sand Slimes Splitting (SSSTT)			12		13										7.- Coemin	8.- Delta
Conventional Tailings - Sand Dam - High Raising Rate (CTT - SD - HRR)				14,15	16,17	18									9.- Cerro Negro	10.- Sierra Gorda
Conventional Tailings - Sand Dam - Low Raising Rate (CTT - SD - LRR)										15					11.- Esperanza	12.- Mantos Blancos
Conventional Tailings - Borrow Dam - High Raising Rate (CTT - BD - HRR)				20,21							22				13.- La Brea / Acopio Arenas	14.- Los Quillayes
Conventional Tailings - Borrow Dam - Low Raising Rate (CTT - BD - LRR)							23				24	25			15.- Mauro	16.- Quebrada Enlozada
	85	82	79	76	73	70	67	64	61	58	55	51	48	17.- Quebrada Linga	18.- Quebrada Cortadera	
	Cw % (Tailings solid content)														19.- Quebrada Honda	20.- Candalaria
															21.- Los Diques	22.- Laguna Seca
															23.- Carmen de Andacollo	24.- Talabre
															25.- Pampa Pabellón	

Cacciuttolo, C., & Valenzuela, F. (2022). Efficient Use of Water in Tailings Management: New Technologies and Environmental Strategies for the Future of Mining. *Water*, 14(11), 1741. <https://doi.org/10.3390/w14111741>



Today's Hypothesis

- Minerals processing causes (but can also solve) many of the problems in tailings dewatering and storage – in some cases as the most important factor.
- Particle size affects dewatering efficiency and physical properties of tailings
 - Fine particles – like clays or silts – tend to hold onto water more stubbornly due to their high surface area and colloidal behaviour, slowing down drainage and increasing the energy needed for dewatering
 - Coarser particles, on the other hand, drain more freely
 - PSD matters
- Managing particle size distributions (PSD) by performing tailored size separations ahead of dewatering equipment will lead to more efficiently dewatered tailings
- Dewatering approaches should be tailored to suit the best deposition/placement strategy

Why this hypothesis?

- Evidence suggests it simply does not make sense to dewater coarse and fine together
- A one-size-fits-all approach through conventional dewatering equipment causes problems; coarse particles cause accelerated wear and consume volumetric capacity
- Evenly graded size distributions dewater worse than separate or bi-modal distributions
- Fine streams need more dewatering 'effort' than coarse streams



Tailings Game Rules Outline

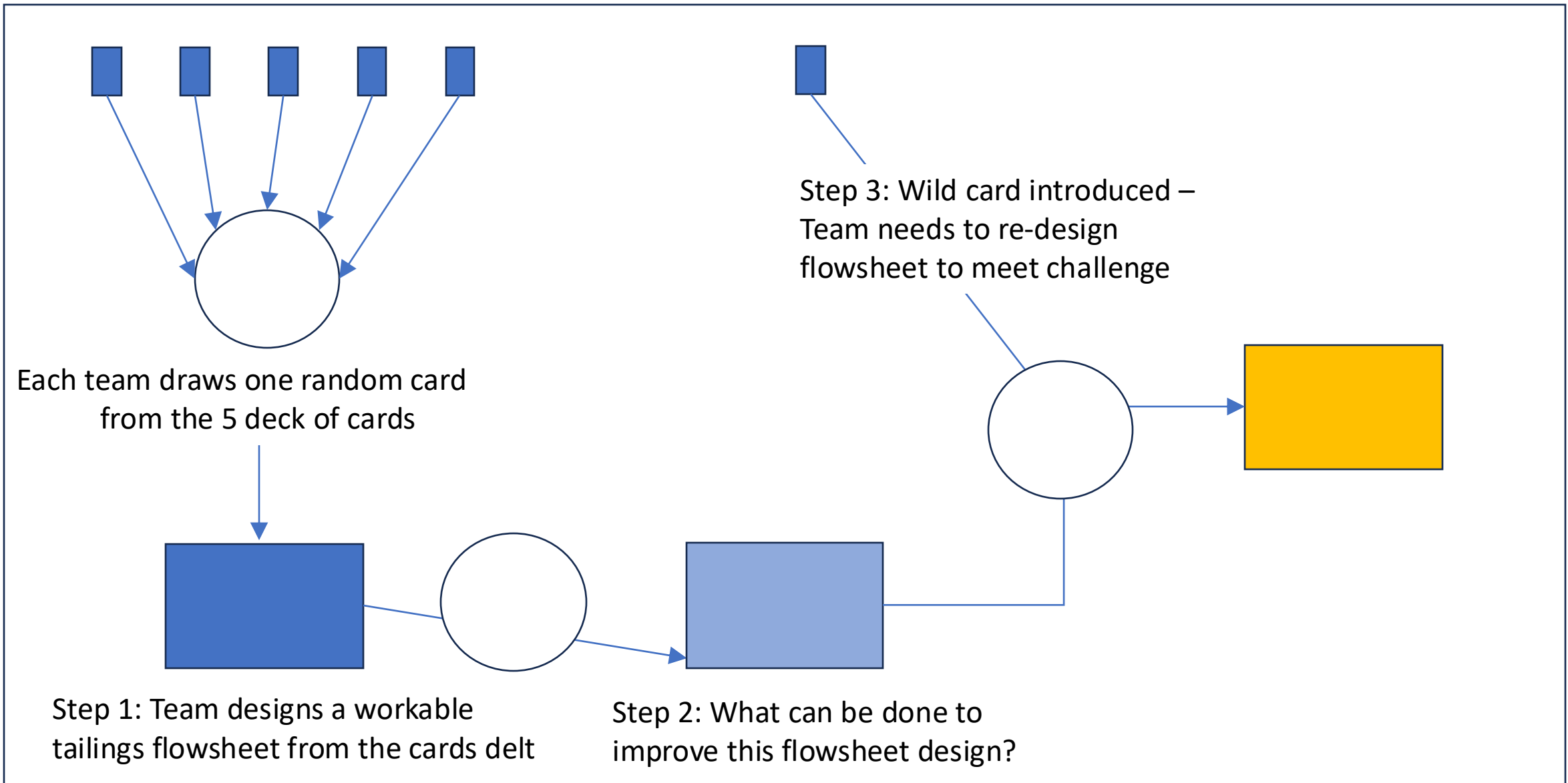

Working Flowsheet

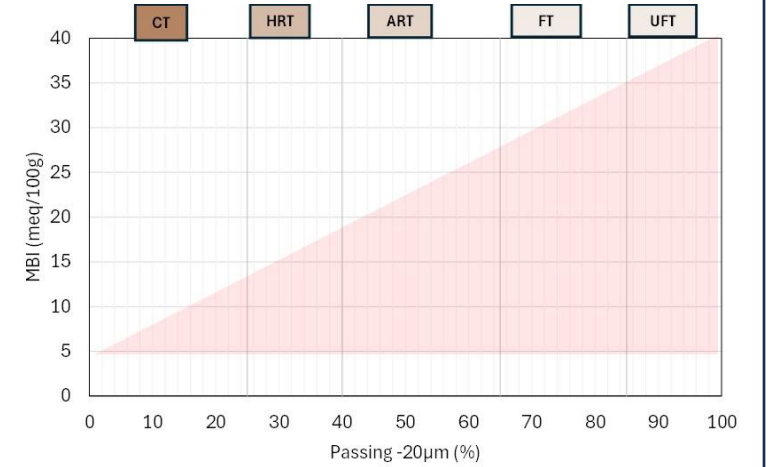
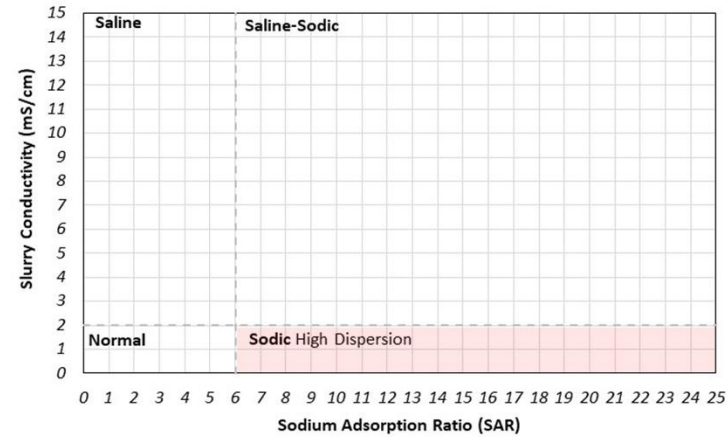
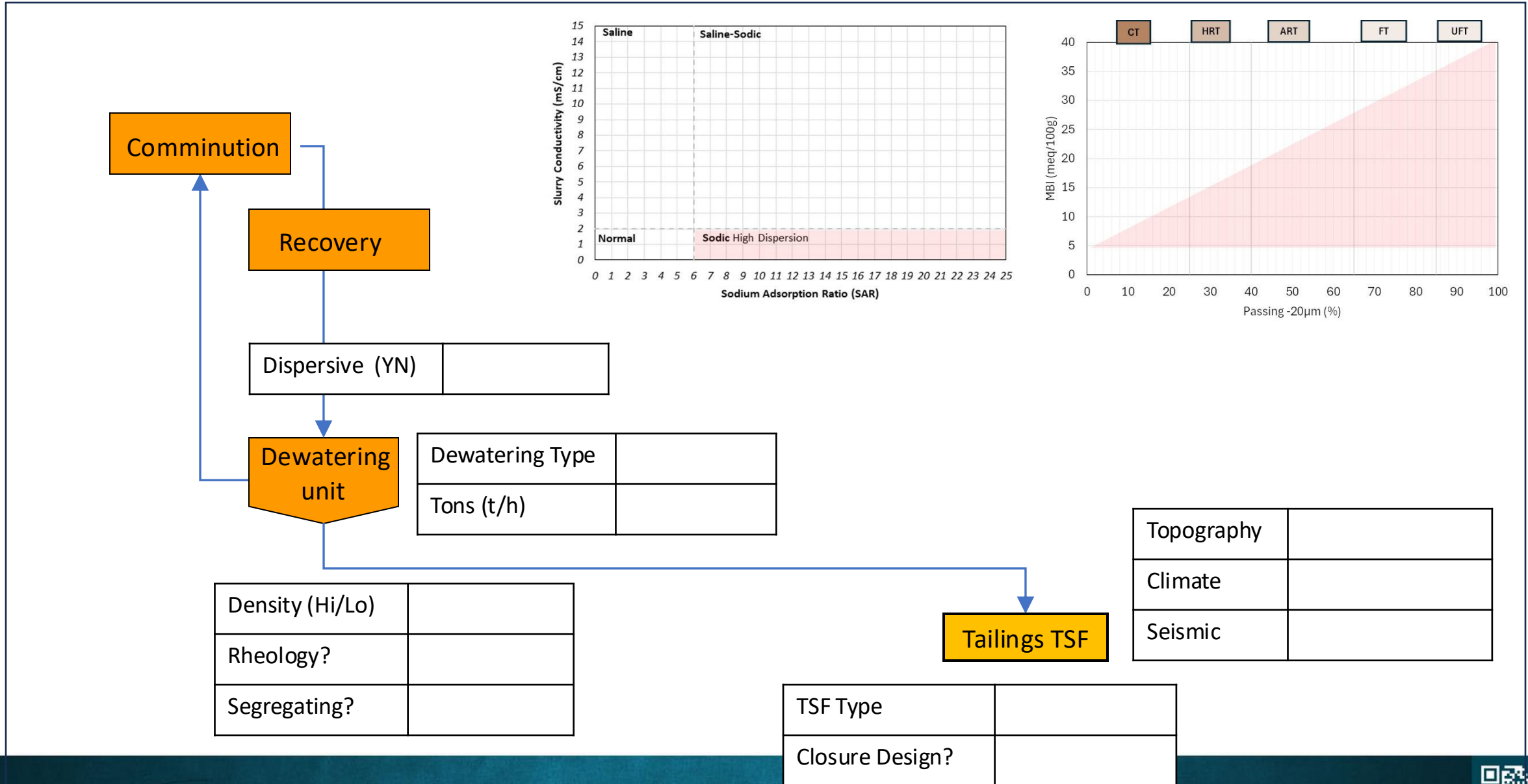

Comminution

Recovery

Dispersive (YN)	
-----------------	--

Dewatering unit	Dewatering Type	
	Tons (t/h)	

Density (Hi/Lo)	
Rheology?	
Segregating?	

Tailings TSF

TSF Type	
Closure Design?	

Topography	
Climate	
Seismic	



3

Classifying Tailings

Andrew Vietti

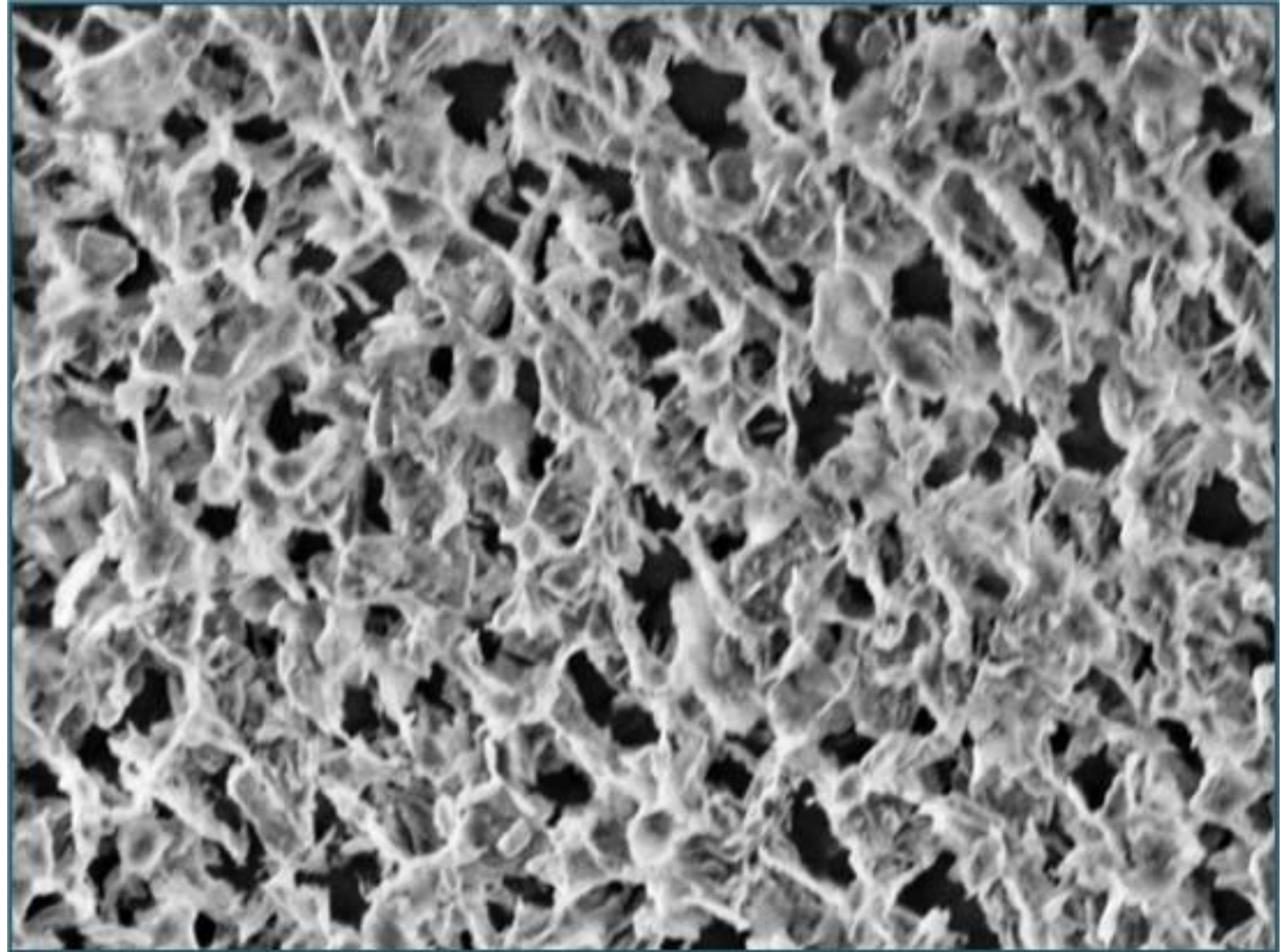

Outline

- Why do we need to classify tailings?
- Why a basic knowledge of clays and water is important
- What a career in clays has taught me (A Vietti)
- What are the key things that people overlook?
- What does this mean for the industry?



Tailings Properties – where are the gaps?

Metallurgical Engineers
Design process flow sheets –
Dewatering type and size

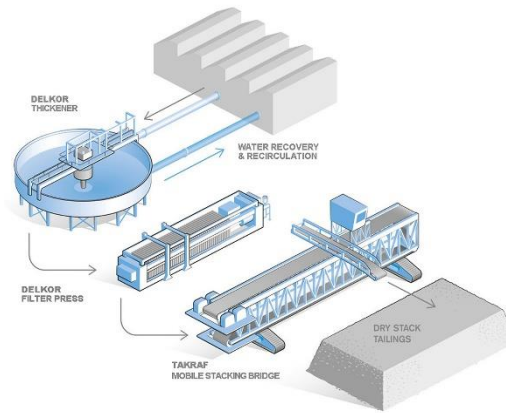

Geotechnical Engineers
Design containment structures –
TSF type and size

Design parameters are based on tailings property data
derived from practical tests

No common ‘language’ to describe tailings properties

No common tailings classification method – particularly for clay containing tailings

TAILINGS



Gap 1: No common language

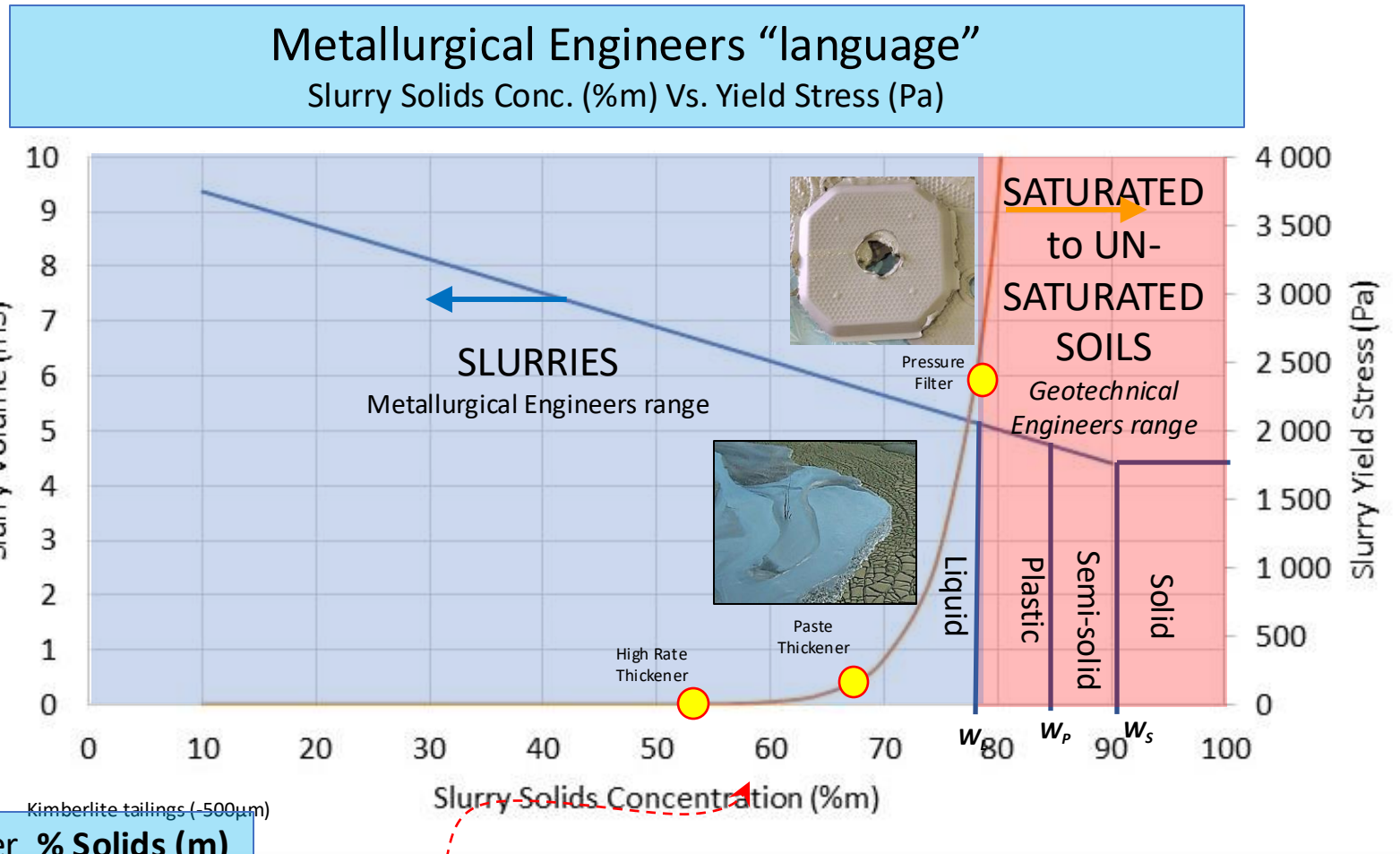

Mets consider **% Solids (m)**



Gap 1: No common language

Geotechnical Engineers "Language"
Slurry Moisture Content (%) Vs. Slurry Volume (m³)

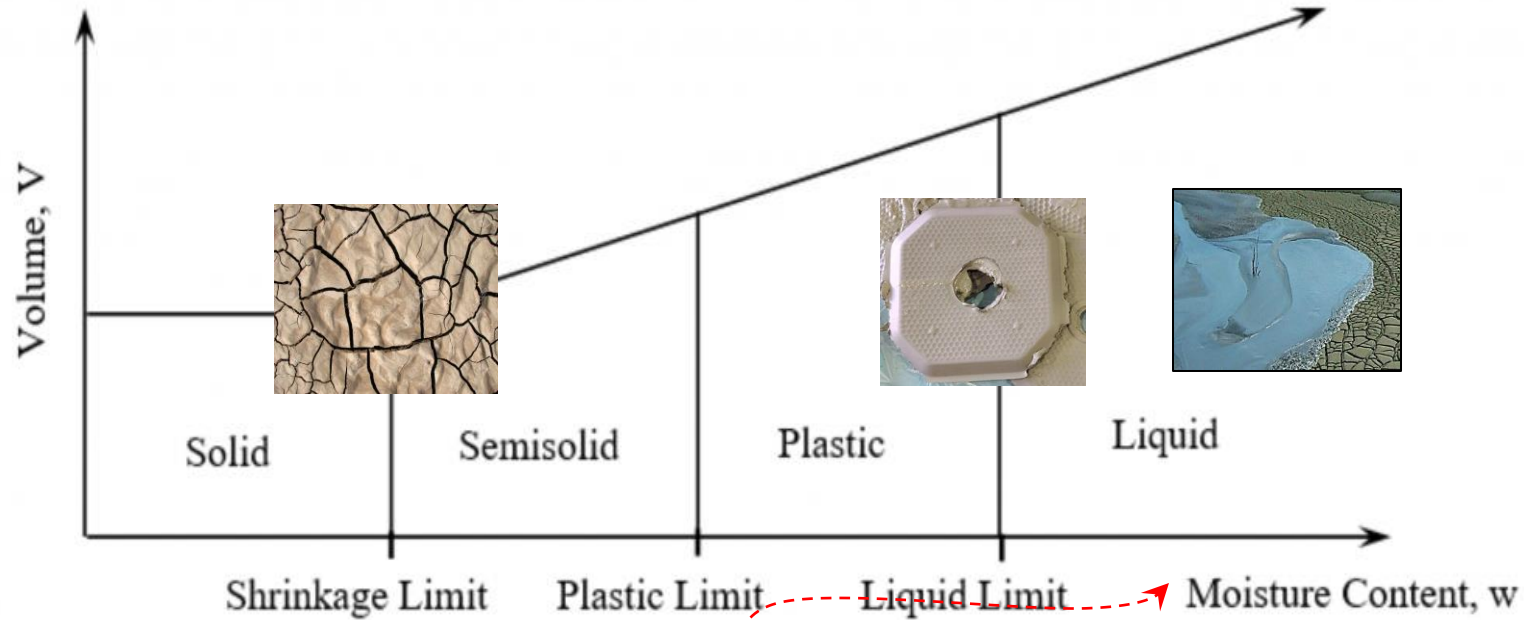

Geotechs consider **% Moisture**

$\frac{\text{Mass Water}}{\text{Mass Solids}}$

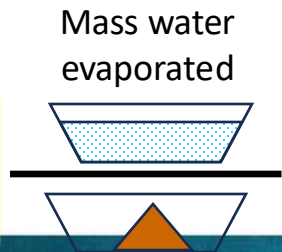

Mets consider **% Solids (m)**

$\frac{\text{Mass Solids}}{\text{Mass Slurry}}$

Mass water evaporated



Gap 1: No common language

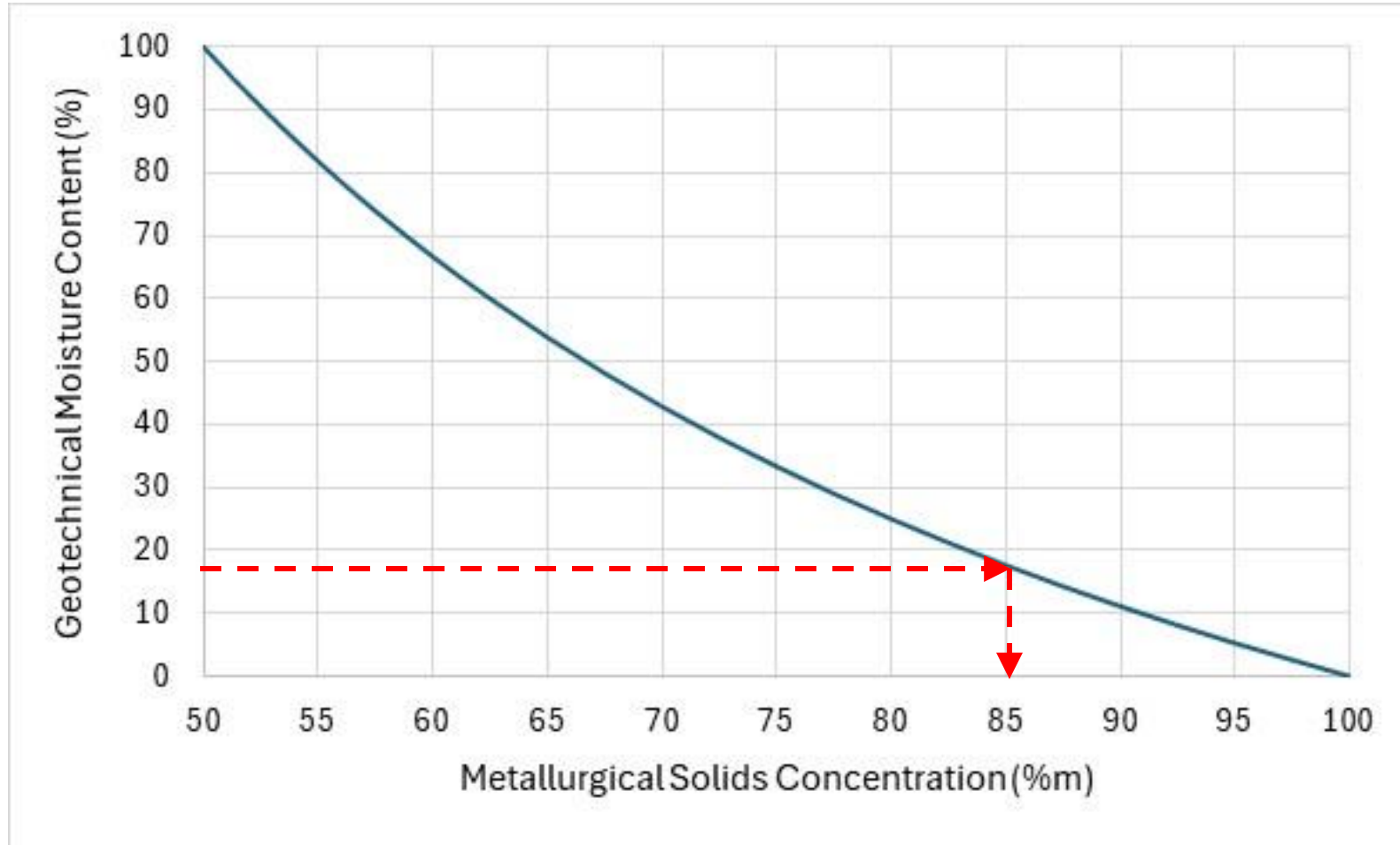

18% moisture = 85%m

(not 100-18 = 82%m)



Gap 2 – No common tailings classification method

- Geotechnical Engineers commonly use the Unified Soil Classification System (USCS) for soils.
- Classify by particle size (intrinsic property) and by Atterberg limits (water quality dependent) into cohesive and non-cohesive groups

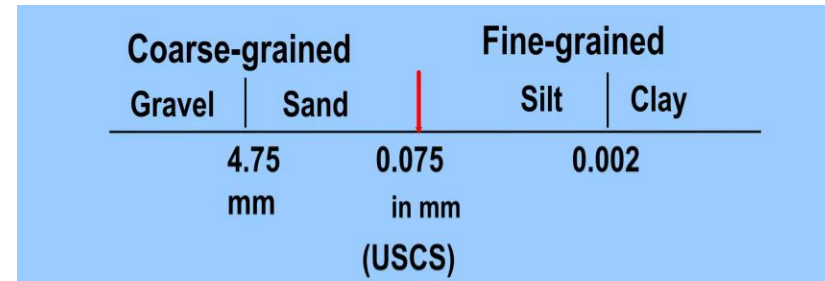
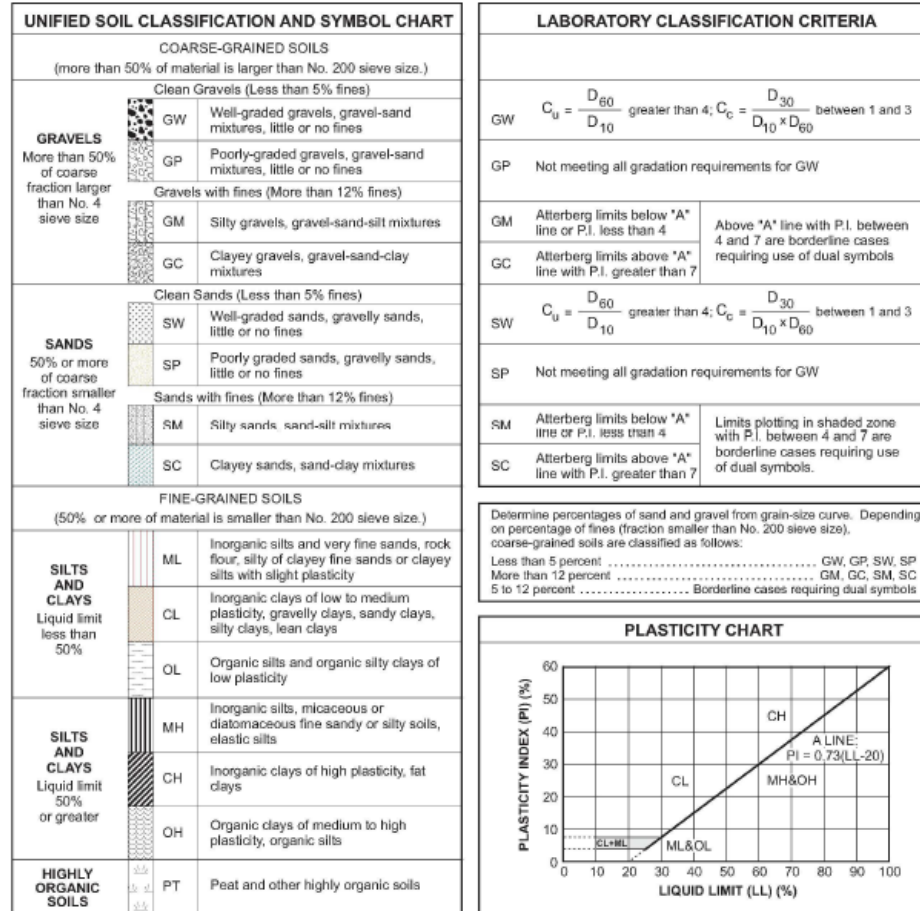

Soil Type	Prefix	Sub Group	Suffix
Gravel	G	Well graded	W
Sand	S	Poorly graded	P
Silt	M	Silty	M
Clay	C	Clayey	C
Organic	O	LL<50	L
Peat	Pt	LL>50	H

California Dept of Transport – Unified Soil Classification System.



Gap 2 – No common tailings classification method

- Recently (2021) ICOLD introduced a “Tailings Dam Design Technology Update” suggesting tailings be classified into 5 groups.
- Provide “property templates” to classify tailings

Tailings Type	Symbol	Description (compare)	Example of mineral/ore
Coarse tailings	CT	Silty SAND, non-plastic	Salt, mineral sands, coarse coal rejects, iron ore sands
Hard Rock tailings	HRT	Sandy SILT, non to low plasticity	Copper, massive sulphide, nickel, gold
Altered Rock tailings	ART	Sandy SILT, trace of clay, low plasticity, bentonitic clay content	Porphyry copper with hydrothermal alteration, oxidized rock, bauxite, leaching processes
Fine tailings	FT	SILT, with trace to some clay, low to moderate plasticity	Iron ore fines, bauxite (red mud), fine coal rejects, leaching processes, metamorphosed/weathered polymetallic ores
Ultra Fine tailings	UFT	Silty CLAY, high plasticity, very low density and hydraulic conductivity	Oil sands (fluid fine tailings), phosphate fines; some kimberlite and coal fines

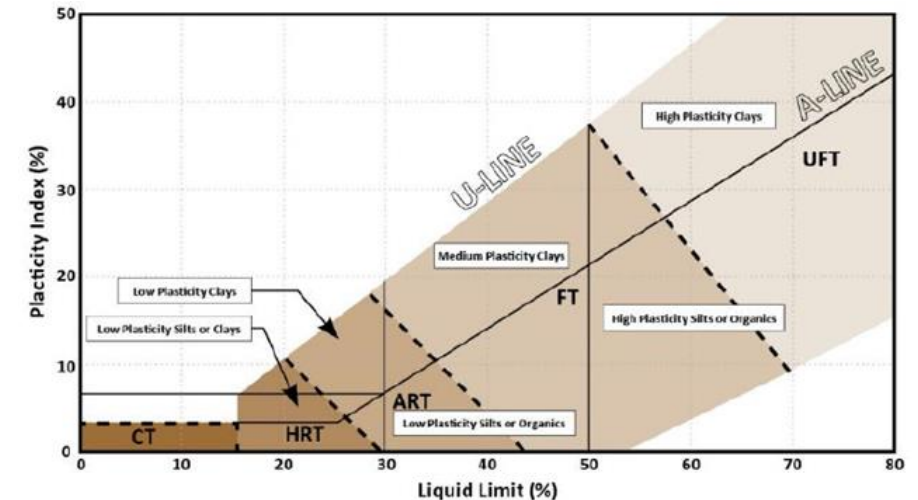
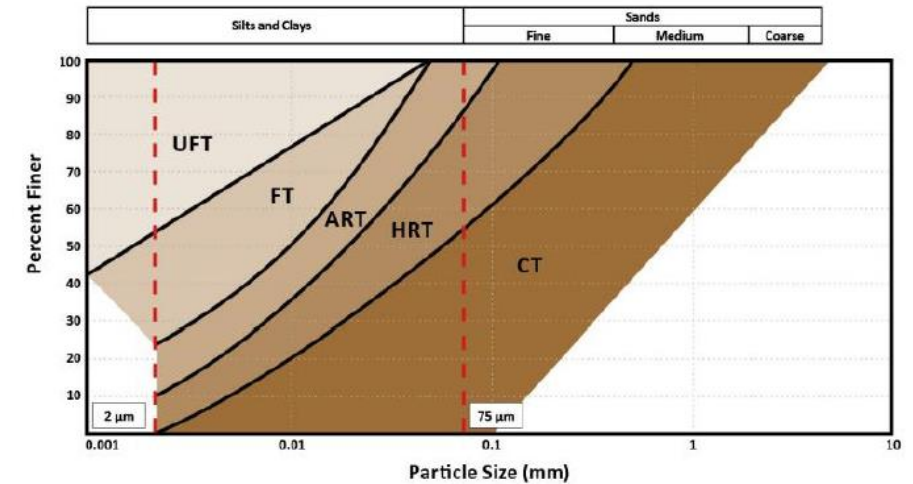

International Commission on Large Dams 2021, *Bulletin 181 Tailings Dam Design Technology Update*, Paris.



Gap 2 – No common tailings classification method

- Important questions to consider when classifying clay containing (cohesive) tailings

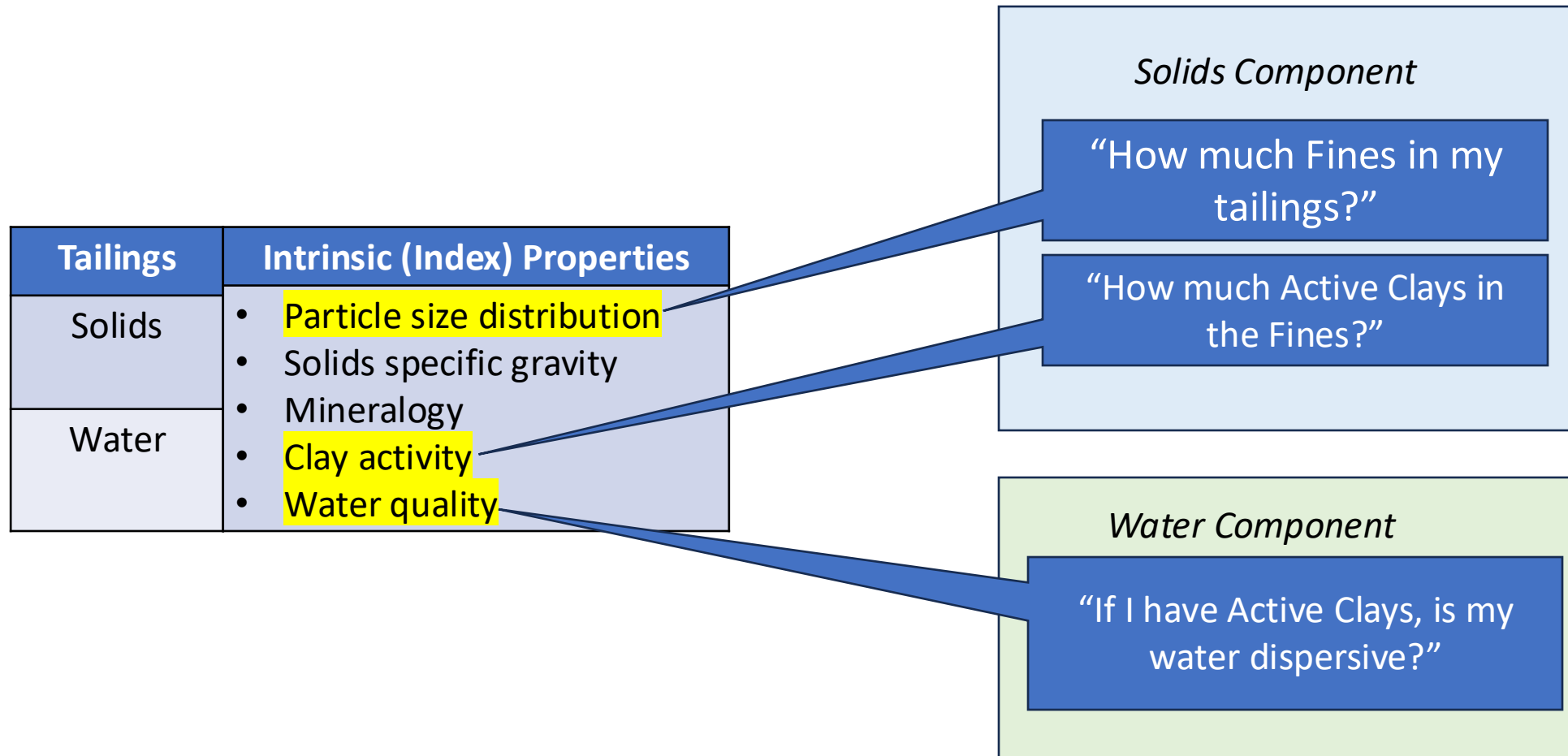

Classifying Tailings: Solids Component

- How much Fines do I have in my tailings?

Solids Particle Size

- Define -20 μm as “Fines” fraction (rather than -2 μm as “Clay”)
- Accepted as a valid criteria for classifying tailings behavior for dewatering and backfill applications

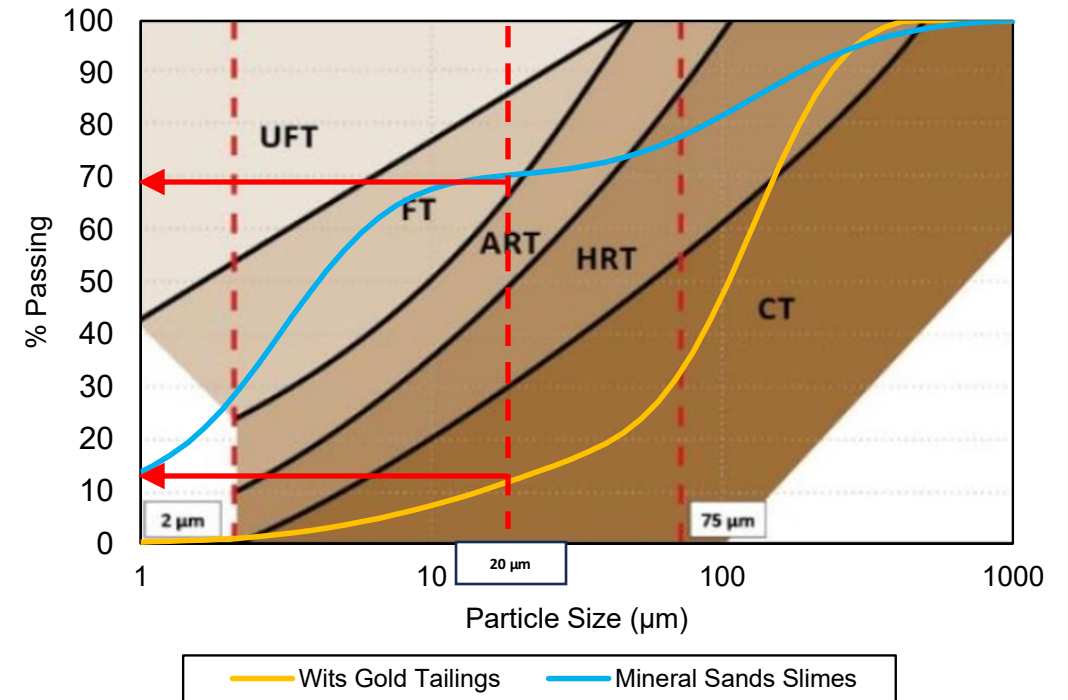
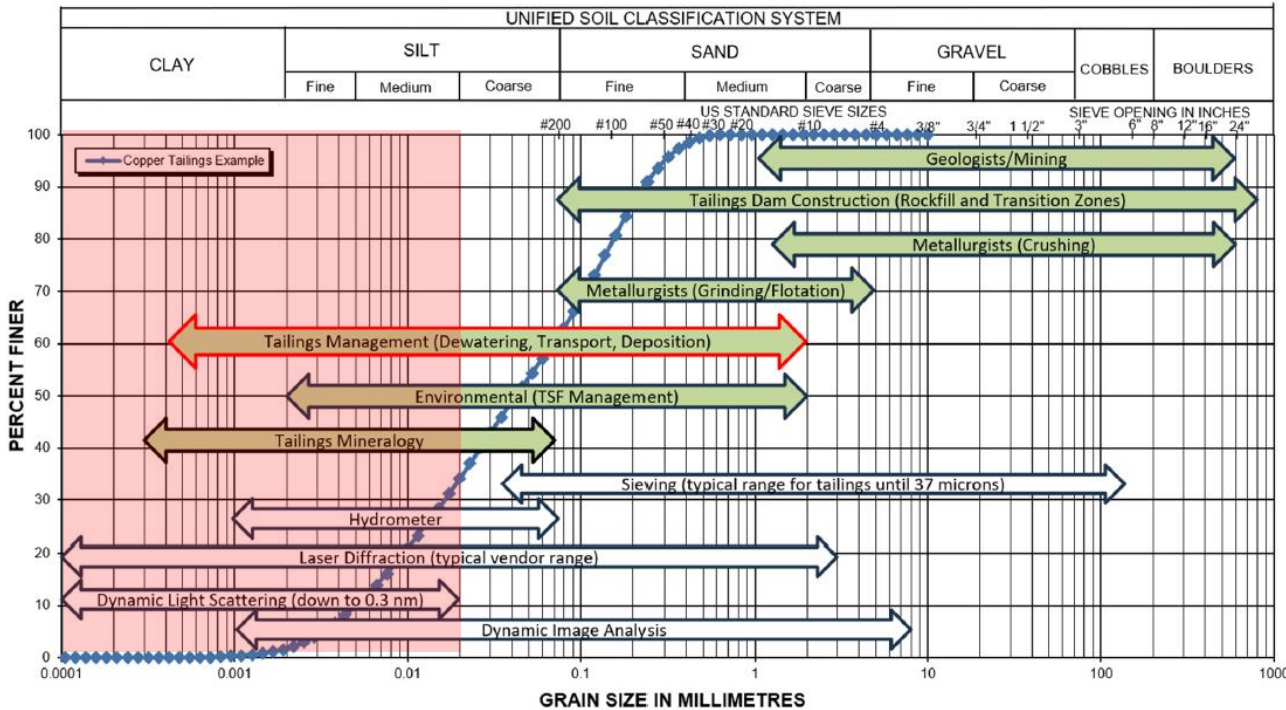

Engels, J, Guzman, J & Valdes, S 2025, 'Tailings particle size distribution methodology: the good, the bad, and the ugly', in AB Fourie, A Copeland, V Daigle & C MacRobert (eds), *Paste 2025: Proceedings of the 27th International Conference on Paste, Thickened and Filtered Tailings*, Australian Centre for Geomechanics, Perth, pp. 165-180,



Classifying Tailings: Solids Component

- How much Active Clays do I have in my Fines?

Active Clays have charged surfaces

- EDGES* – negative or positive charge depending on pH when in water.
- SURFACE* – negative which can exchange cations when in water.

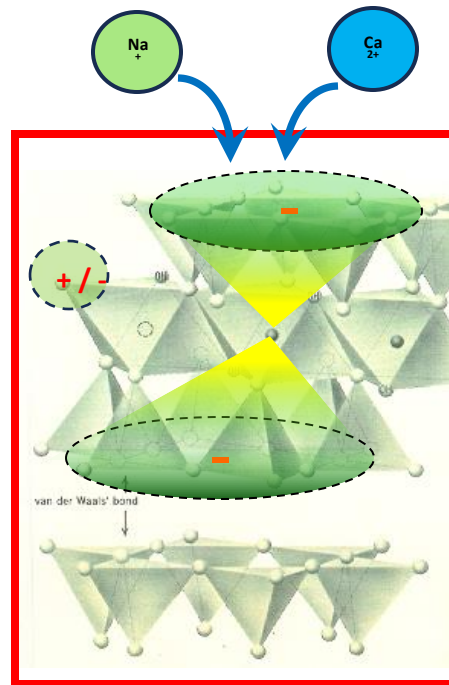

Type	Charge on layer	Dioctahedral	Trioctahedral
1:1	(x ~ 0)	Kaolinite kaolinite, dickite, nacrite, halloysite	Serpentine amesite, chrysotile, antigorite, lizardite
	(x ~ 0)	Pyrophyllite	Talc
2:1	(x ~ 0.2 – 0.6)	Smectite montmorillonite, beidellite, nontronite	Smectite saponite, hectorite, stevensite
	(x ~ 0.6 – 0.9)	Vermiculite	Vermiculite
	(x ~ 0.75 – 0.9)	Illite Glauconite	
	(x ~ 1.0)	Micas muscovite, paragonite, phengite, celadonite	Micas phlogopite, biotite, lepidolite
	(x ~ 2.0)	Brittle micas margarite, clintonite	
	(x ~ variable)	Chlorites donbassite	Chlorites clinochlore, chamosite, ripidolite
	(x ~ variable)		Sepiolites, Palygorskites

Active/Swelling Clays

Grimm, RE, 1968, 'Clay mineralogy (2nd ed)', McGraw Hill, New York.



Classifying Tailings: Solids Component

- How much Active Clays do I have in my Fines?

Clay Activity (expressed surface charge)

- Methylene Blue Index Method - Dye titration method to determine clay surface charge/area
- Standard Test Method for Methylene Blue Index of Clay (ASTM Standard C837)
- Define <15 meq/100g threshold as lower limit of Active/Swelling clay

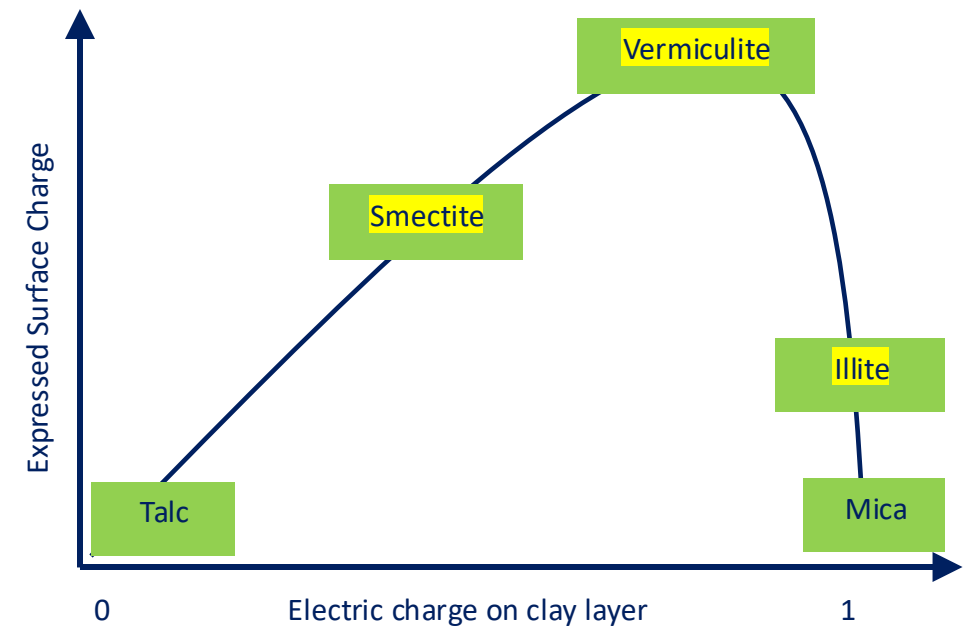
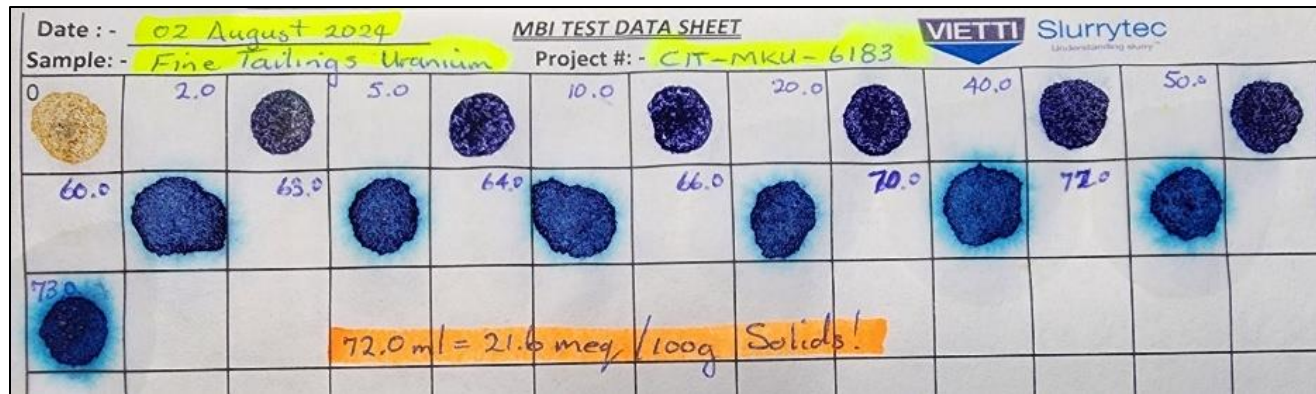

Kaminsky, H 2014, 'Demystifying the Methylene Blue Index', 4th Int Conf. Oil Sands Proceedings,



Classifying Tailings: Solids Component

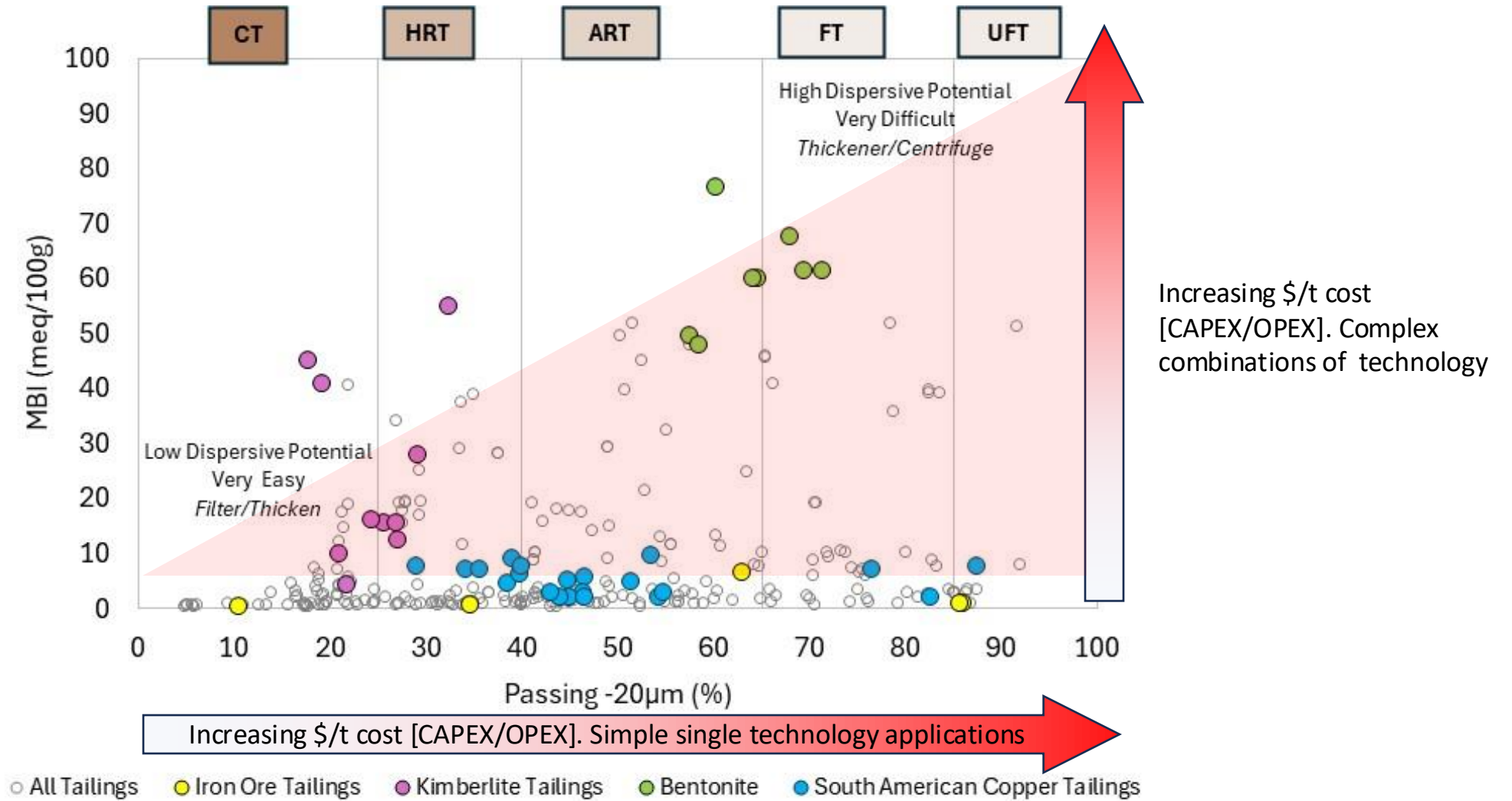

Metallurgical Tricks 1 – Reduce the fines fraction

Coarser grinding

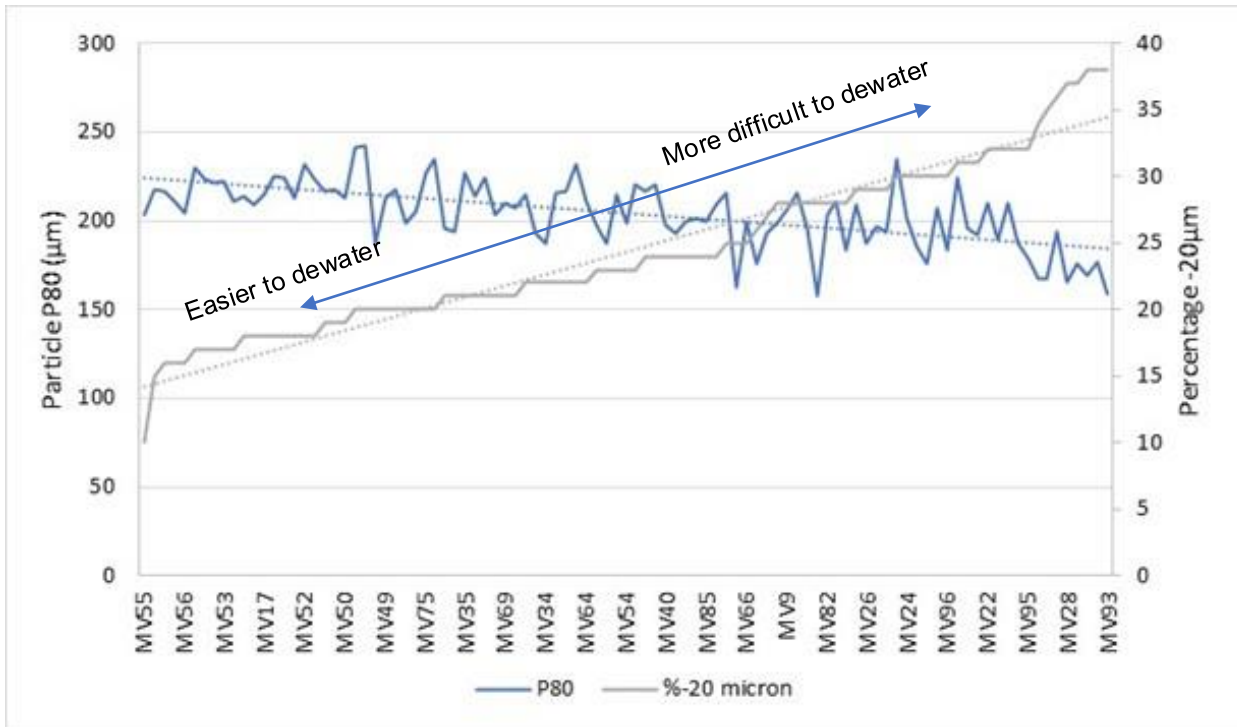

Cyclone classifying

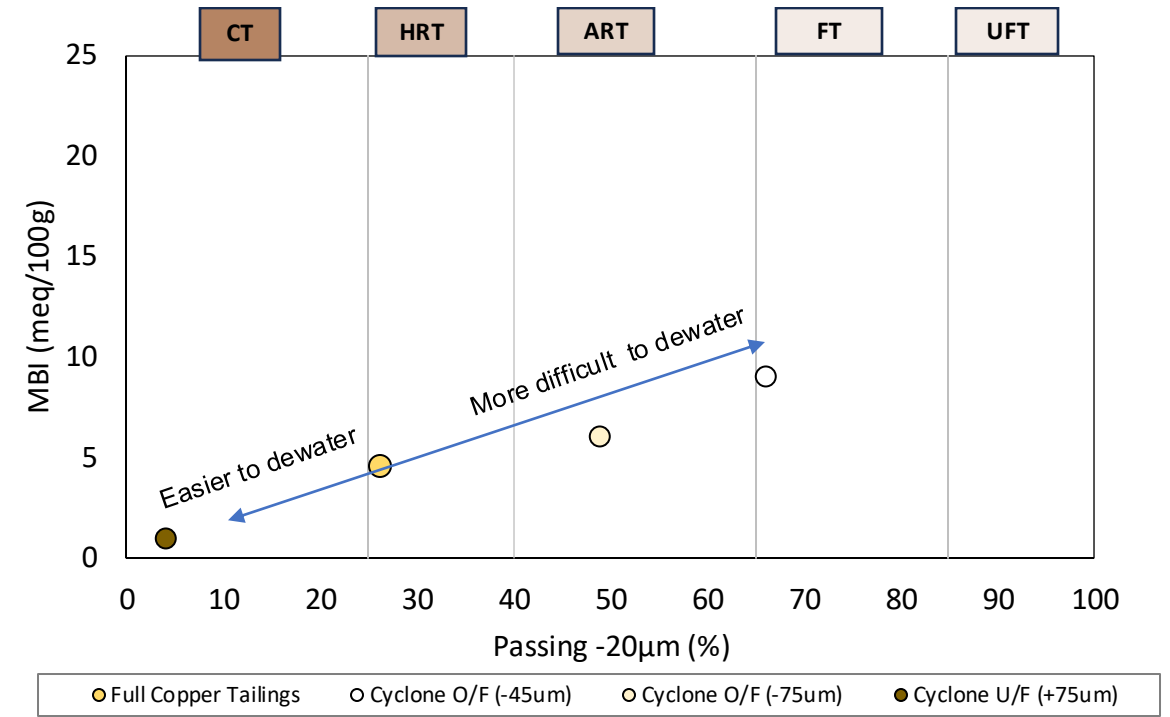

Classifying Tailings: Water Component

- If I have Active Clays, is my water dispersive?

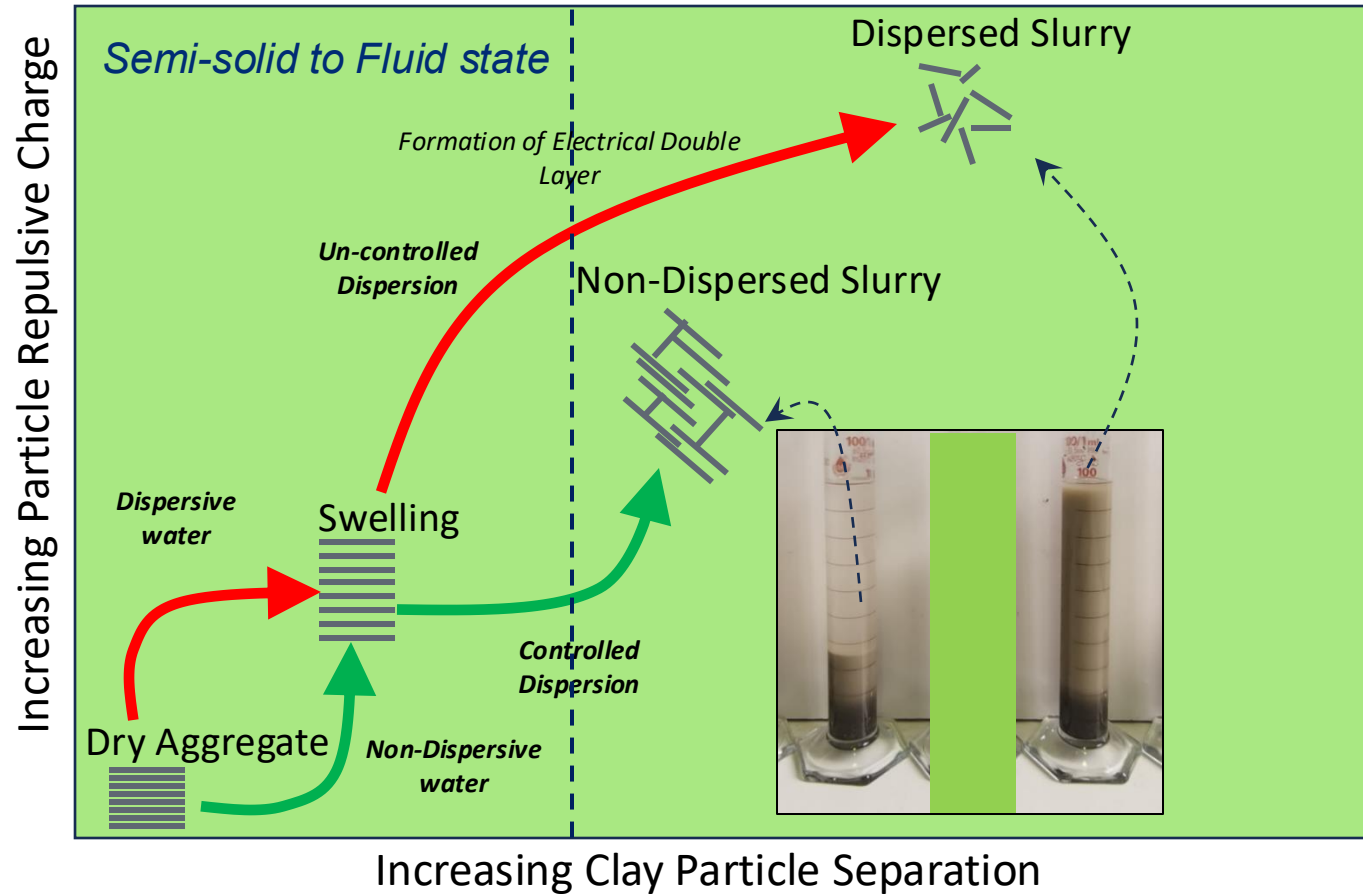

Rengasamy, P 2018, 'Irrigation water quality and soil structure stability – A perspective with some new insights'. Agronomy, 8, pp 72-85.



Classifying Tailings: Water Component

- Tailings containing Active Clays have similar DISPERSIVE properties as Saline/Sodic soils

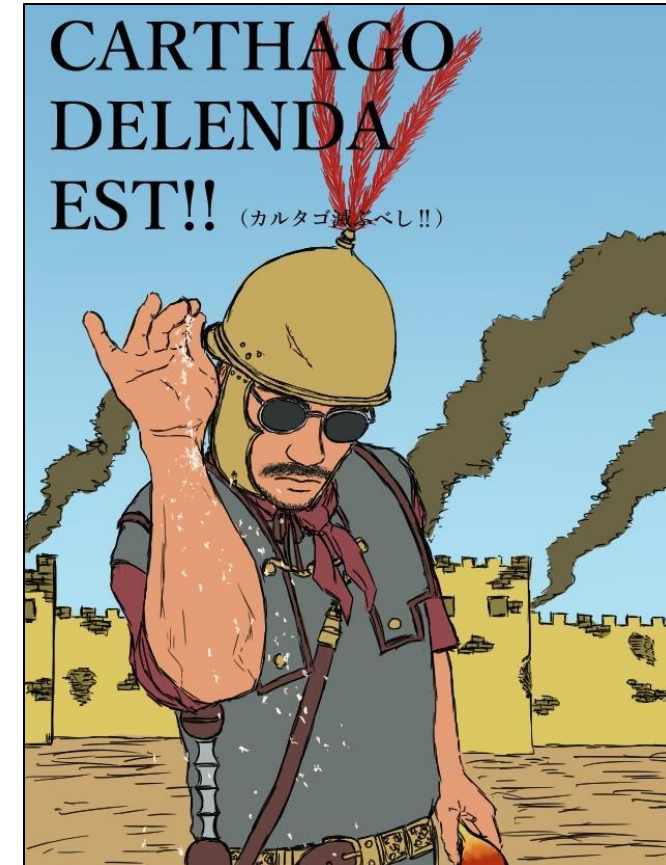
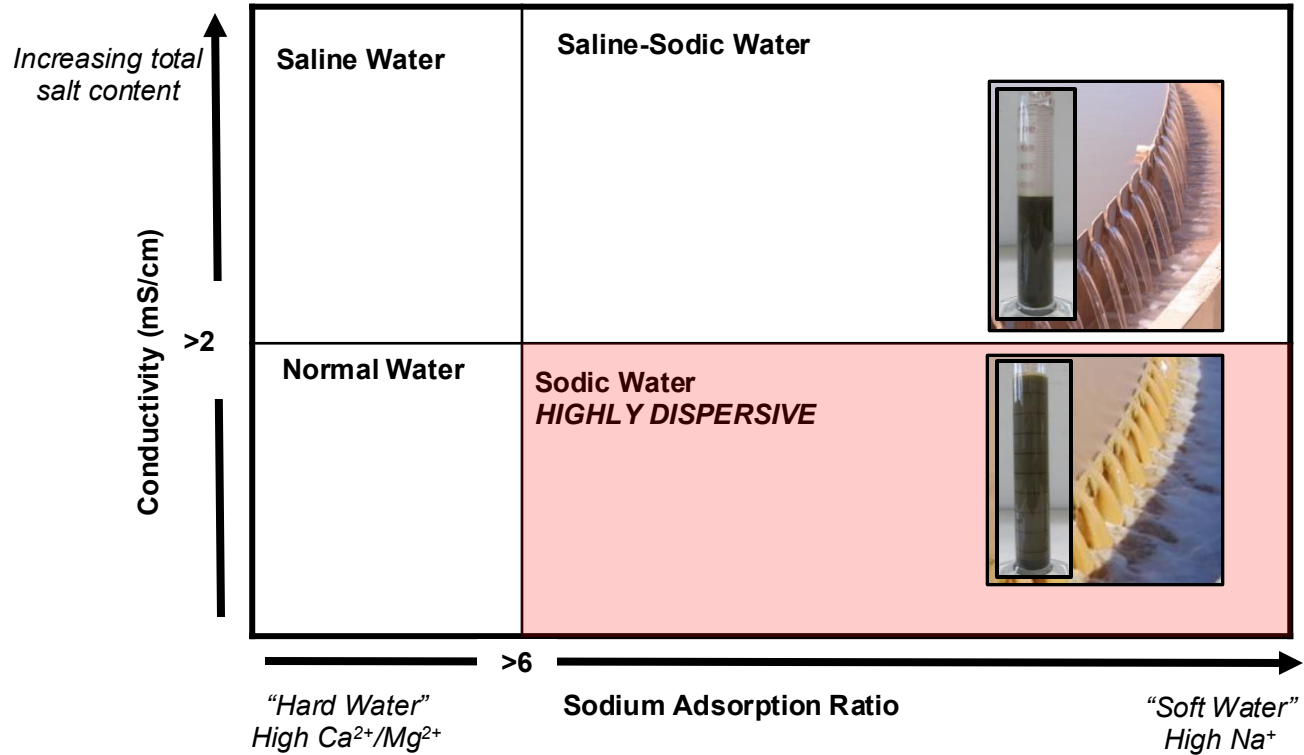

Fitzpatrick, RW, Boucher SC, Naidu R and Fritsch E 1994, 'Environmental consequences of soil sodicity' *Australian Journal of Soil Research*, vol 32, pp 1068-1093.



Classifying Tailings: Water Component

1. Conductivity of Water (mS/cm)

- Measured by conductivity meter
- Units defined in mS/cm
- Define <2.0 mS/cm as TEC for dispersion

Threshold Electrolyte Concentration(TEC)

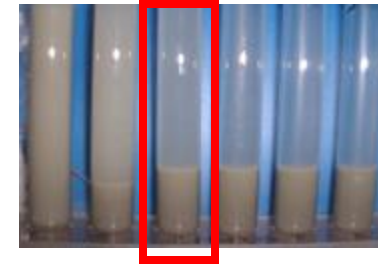

Increasing Conductivity

2. Sodium Adsorption Ratio of Water

- Water Quality Analysis
- Define >6.0 as threshold for dispersion
- Equation (in meq/l):

$$SAR = \frac{Na^+}{\sqrt{\frac{Ca^{2+} + Mg^{2+}}{2}}}$$

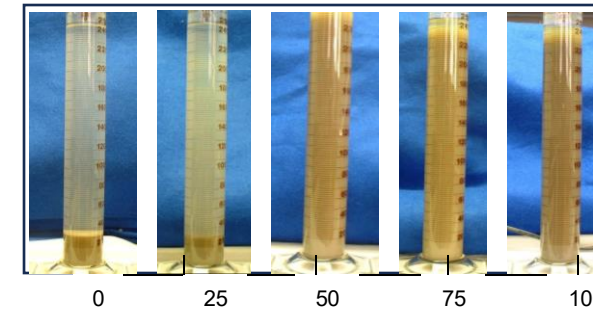

Increasing SAR

3. pH of Water

- Measured using a pH meter
- Define 8 to 10 for dispersion at >6 SAR

SAR <6

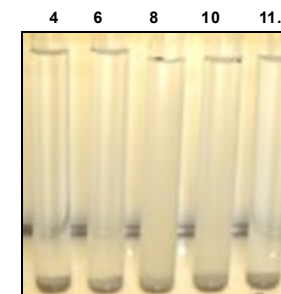

SAR >6

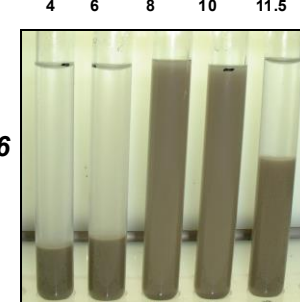

Vietti, AJ 2012, 'Know your chemistry – suspension and compaction behaviour of paste'. in RJ Jewell & AB Fourie (eds), *Proceedings of the 7th International Seminar on Paste and Thickened Tailings*, Australian Centre for Geomechanics, Cape Town.



Classifying Tailings: Water Component

Dispersive slurry



"Hockey stick shape"
Rheological property

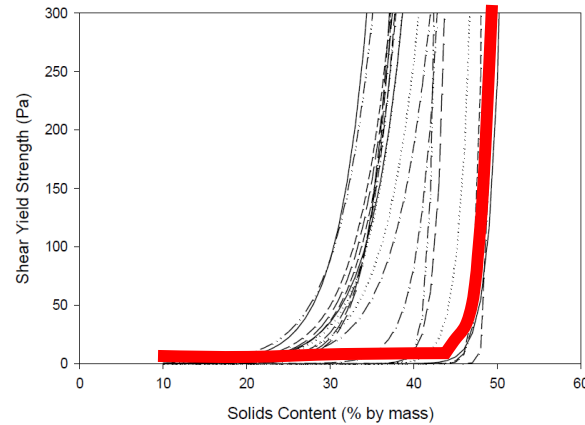

Non-dispersive slurry



"Banana shape"
Rheological property

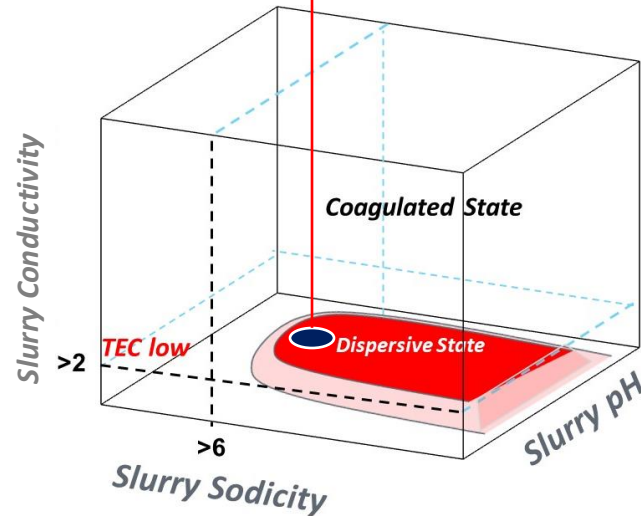
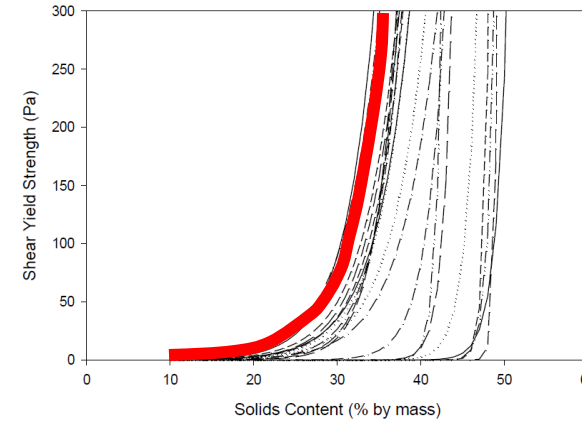

In waters with low Salinity (<math>< 2</math> mS/cm) and Sodicity >6, tailings highly dispersive

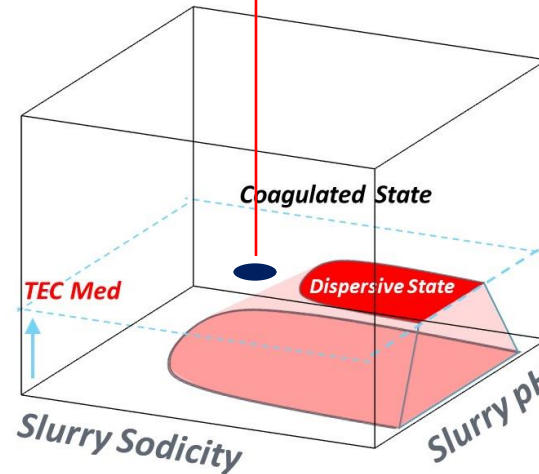

As Salinity increases only tailings with very high Sodicity remain dispersive

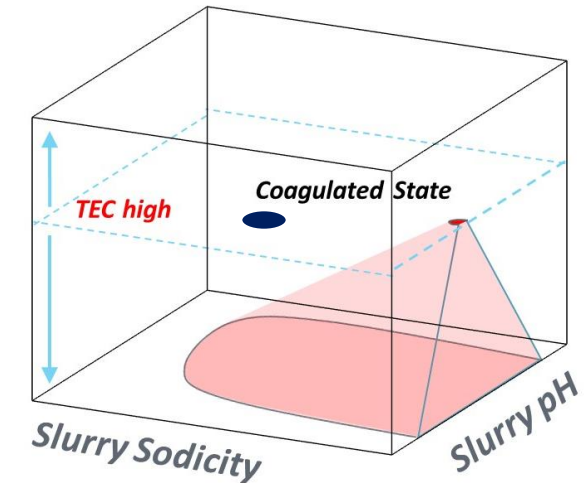

At very high Salinity (sea water) all tailings settle



Metallurgical Tricks 2 – Condition the process water

- “Un-Controlled” dispersed slurries

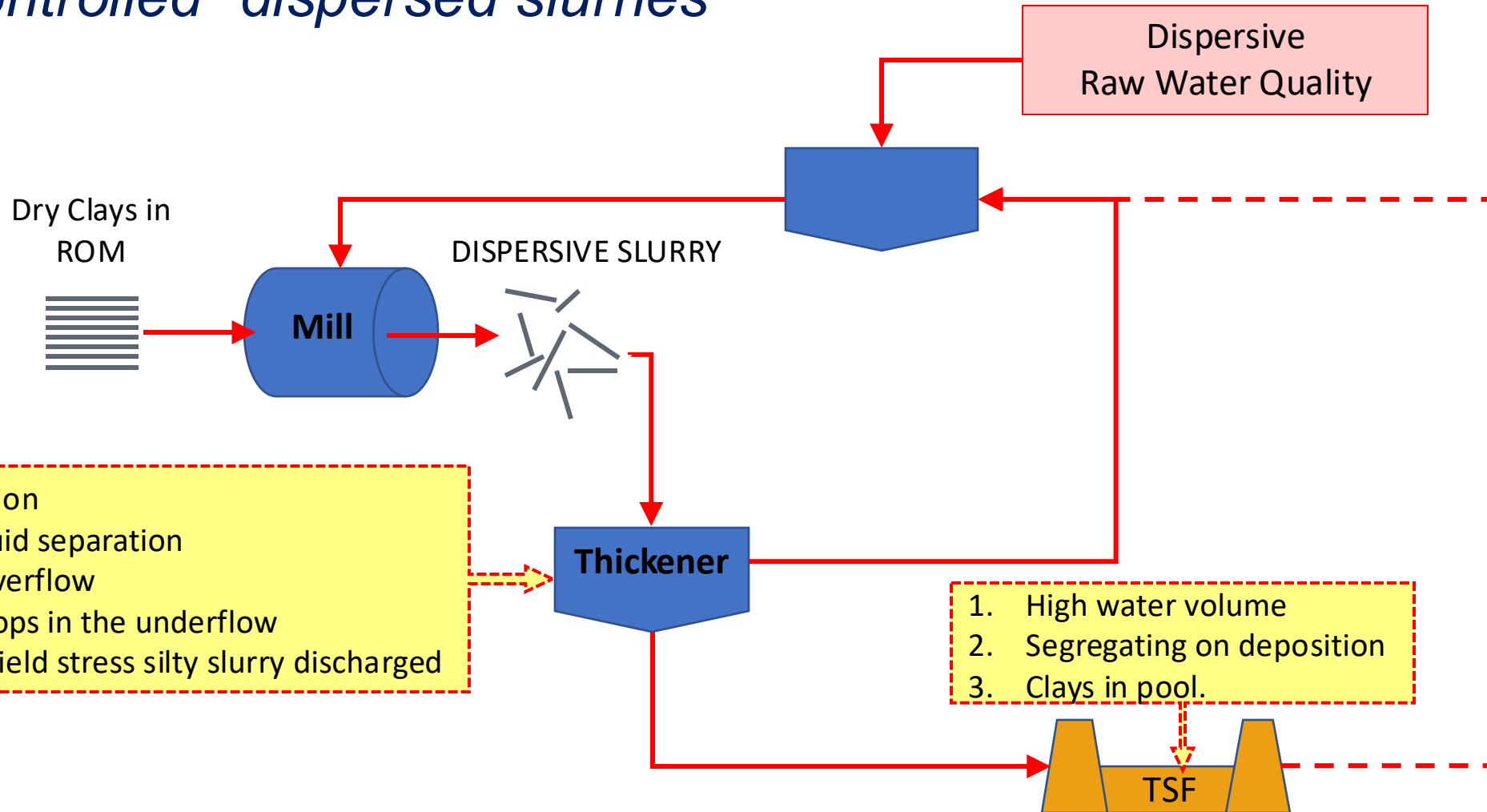

“Un-Controlled” dispersed slurries

OK for Type 1 Mine Archetypes using Conventional tailings disposal into valley impoundments



Catoca Diamond Mine (Angola)



Cullinan Diamond Mine (South Africa)



“Un-Controlled” dispersed slurries

Brutal for Type 1 Mine Archetypes using Paste tailings disposal in constructed impoundments



Jagersfontein Diamond Mine (South Africa)



Metallurgical Tricks 2 – Condition the process water

- “Controlled” dispersed slurries

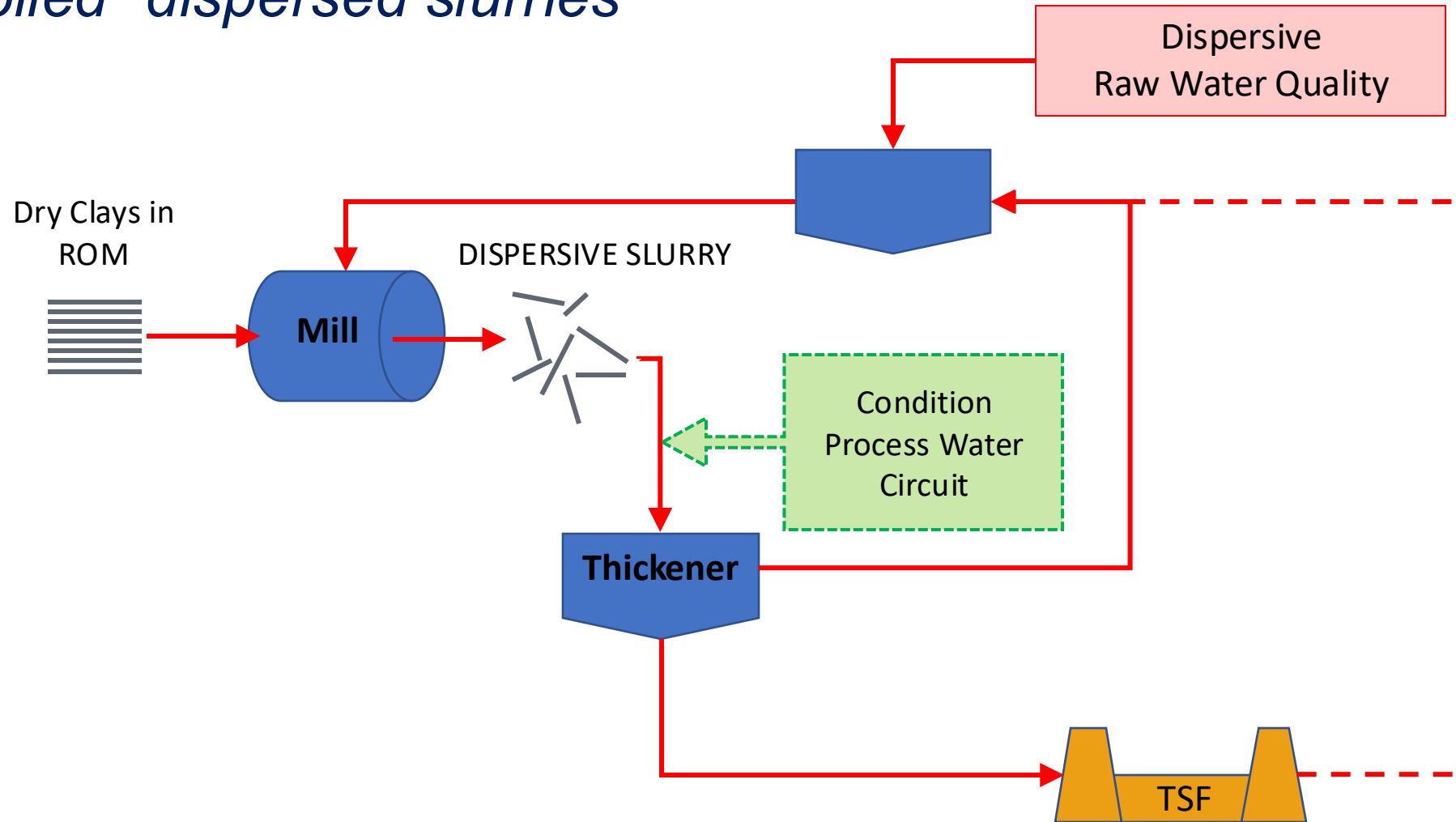

Metallurgical Tricks 2 – Condition the process water

- “Controlled” dispersed slurries

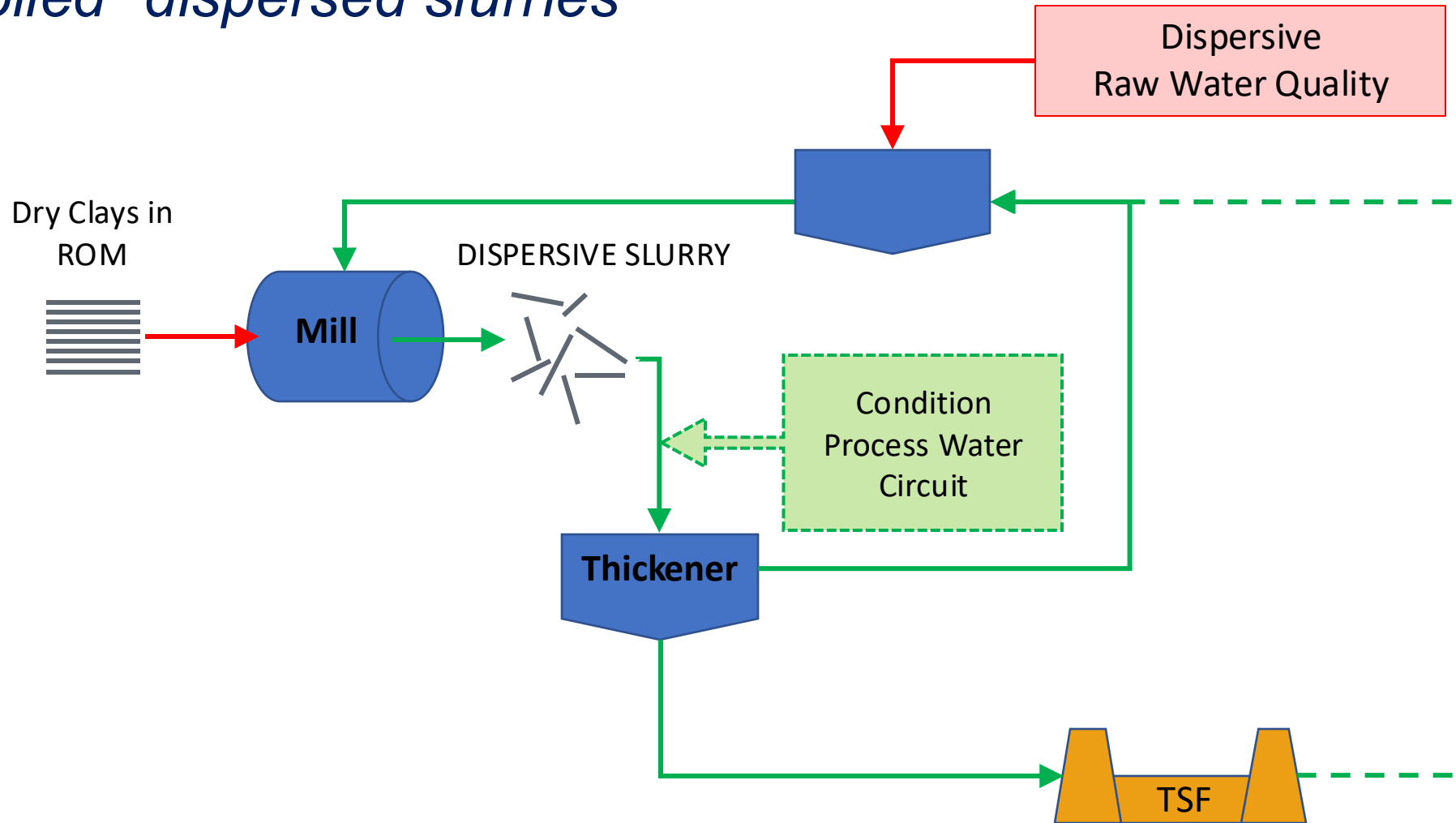

“Controlled” dispersed slurries

OK for Type 1 and 2 Mine Archetypes using Paste tailings disposal in constructed or valley impoundments



Ekapa Diamond Mine (South Africa)

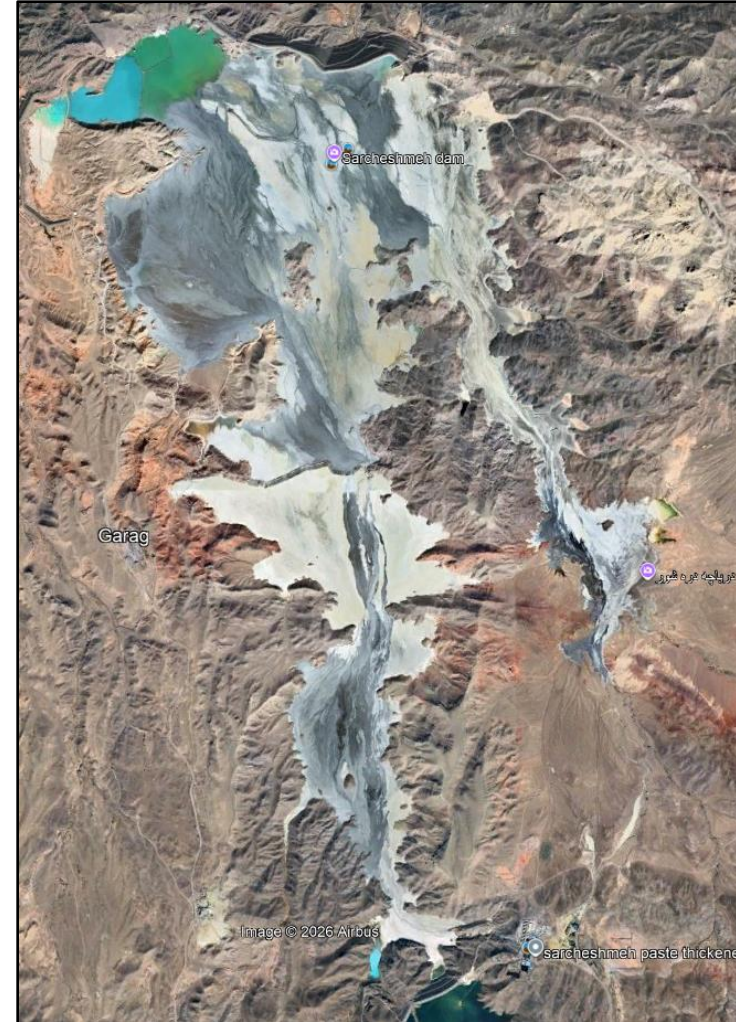

Sar Cheshmeh Copper Mine (Iran)



Where to from here?

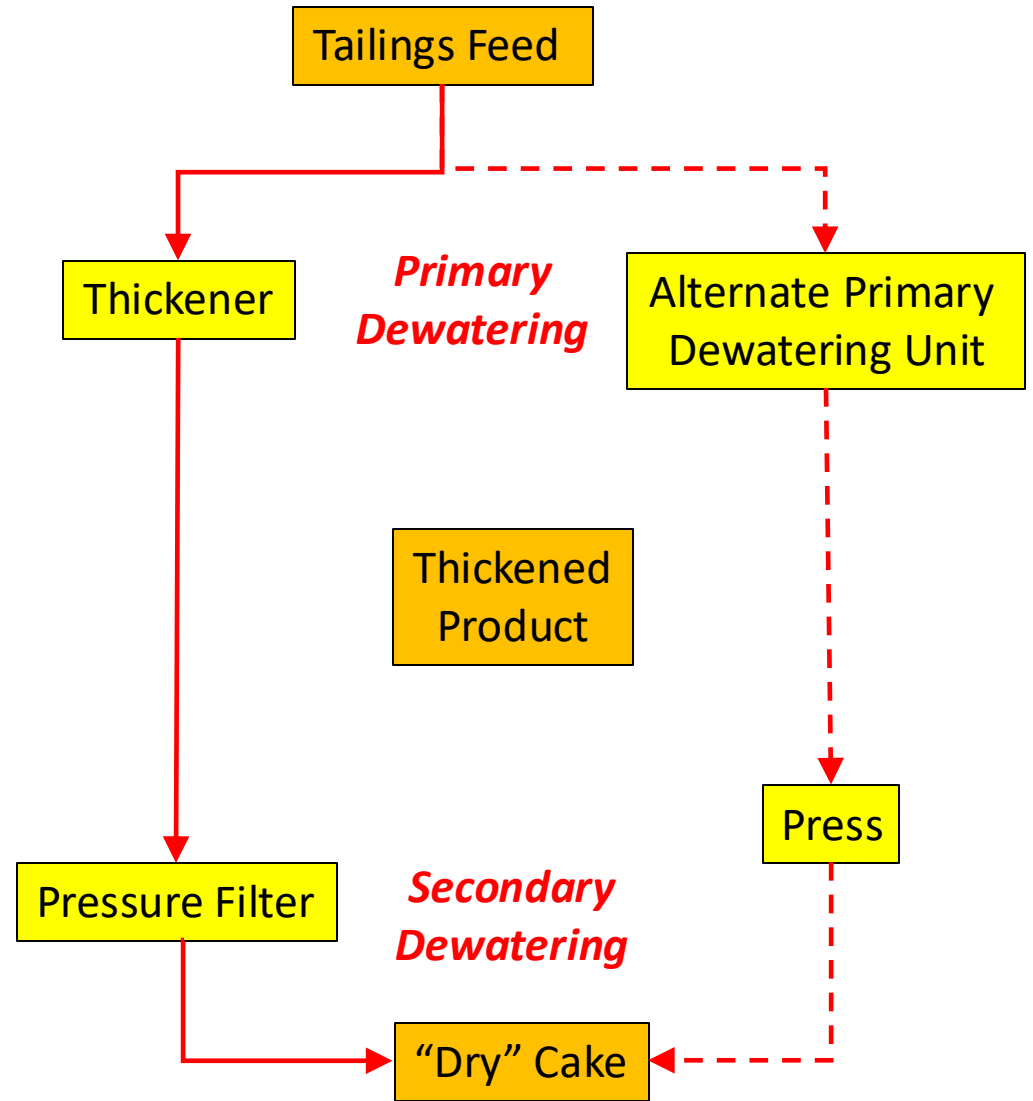
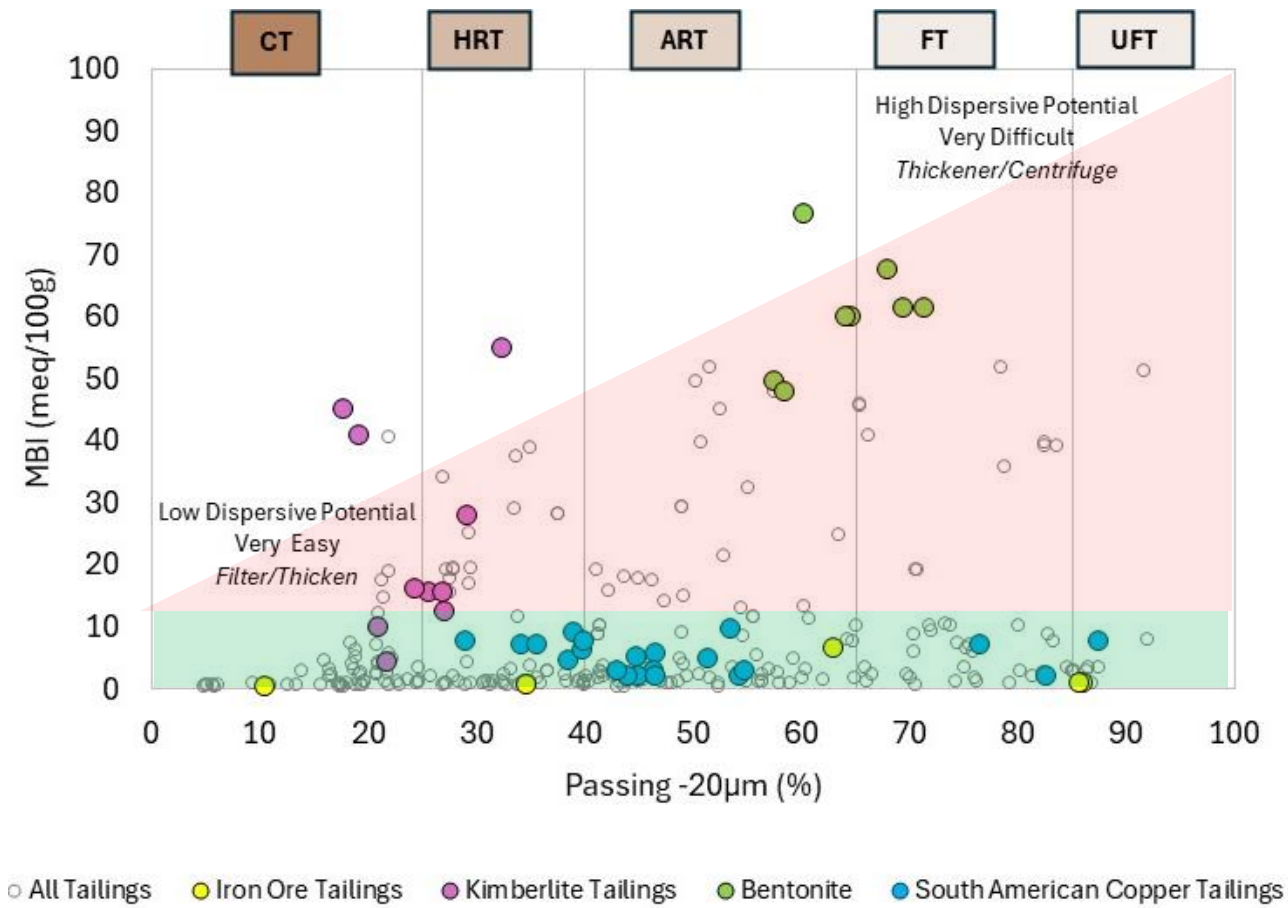

Where to from here?

In-line Flocculation + Static Screening

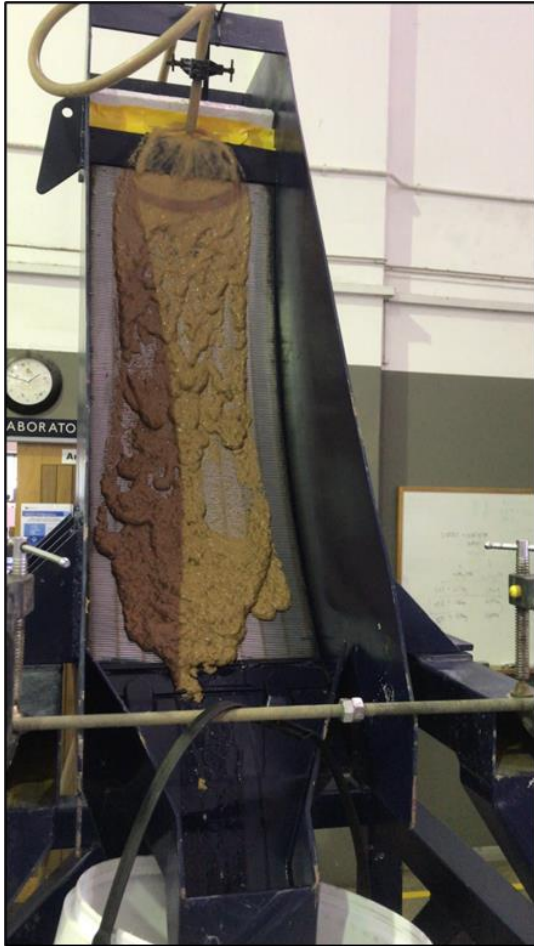

In-line Flocculation + Dynamic Screening (ricotta cheese)



Where to from here?

VST Slack Screen Primary Dewatering Concept

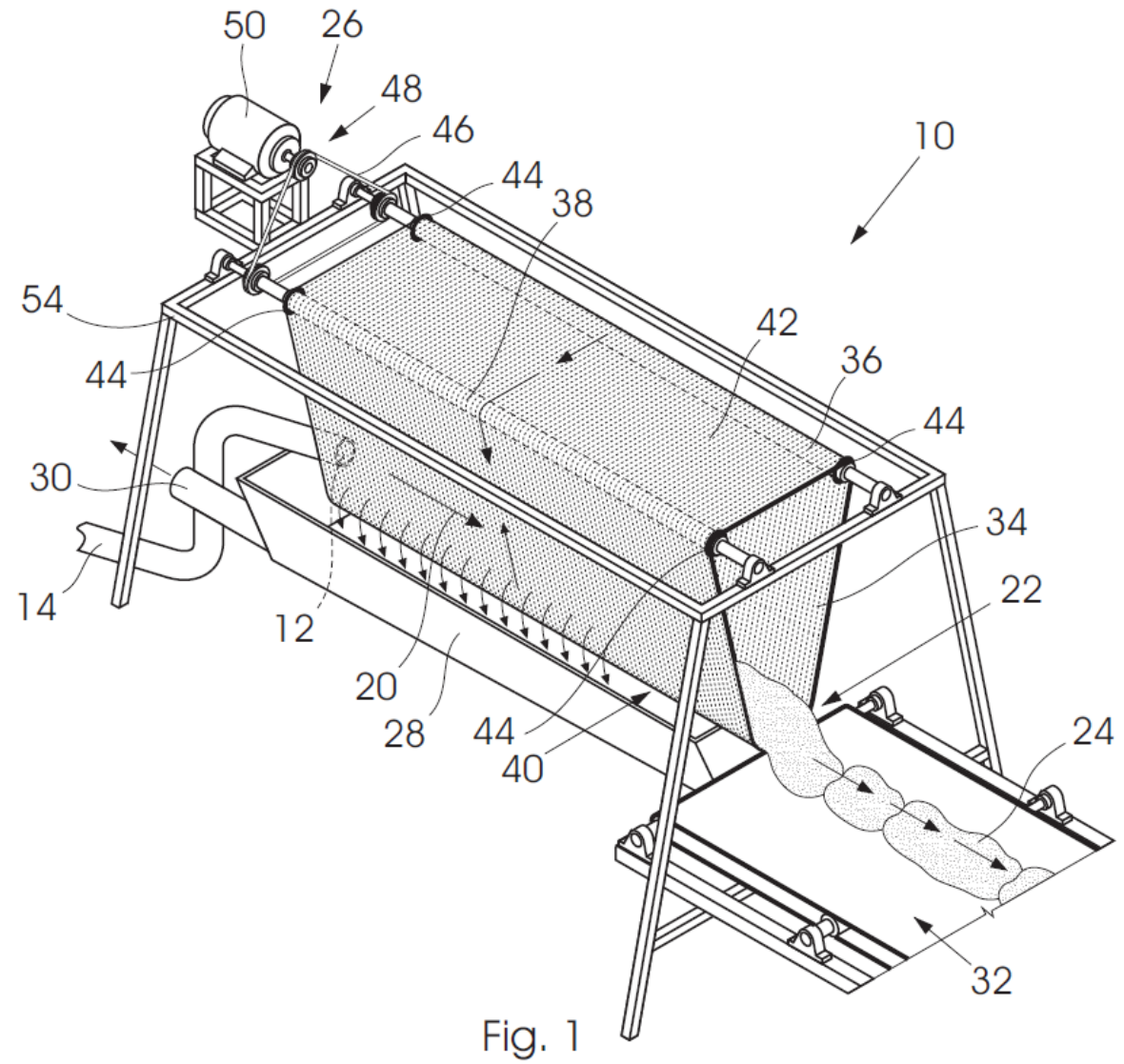

Where to from here?

Slack Screen Primary Dewatering



Belt Press Dewatering



Summary

- Clays are not just small particles
- They are colloidal, meaning they have charges
- They form network structures and bond with water (Van der Waals), making dewatering very difficult
- Their behavior is driven by
 - pH
 - Ionic strength of solution
 - Ca:Na ratios (i.e. the ratio of monovalent, divalent ions in solution)
 - The way in which they disperse for the first time
- Their behaviour can be fundamentally changed by
 - Managing the water chemistry
 - Managing the dispersion characteristics



Clays are very surface active

Mineral	Cation Exchange Capacity (meq/100g at a pH of 7)	Surface Area (m ² /g)	External Surface Area (m ² /g)	Total Surface Area (m ² /g)
Kaolinite	3 – 15	0	15	15
Smectite	80 – 150	750	50	800
Vermiculite	100 – 150	750	<1	750
Illite	10 – 40	5	25	30
Chlorite	10 – 40	0	15	15

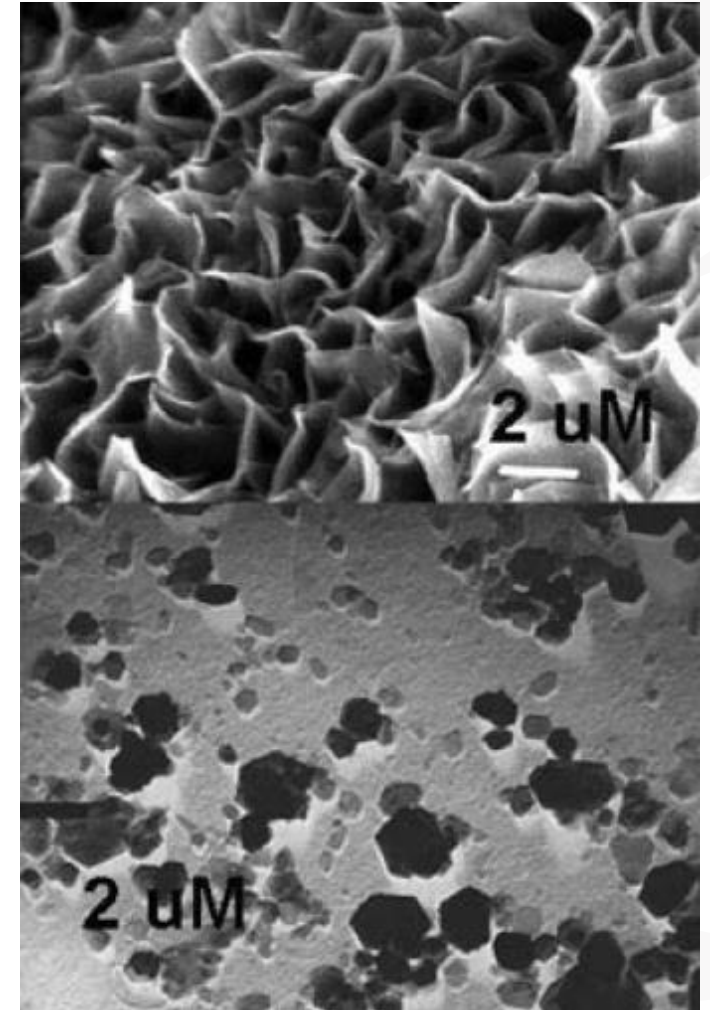

Electron micrographs of Montmorillonite (upper) and Kaolinite (lower) (Cation Exchange: A Review (2011). *International Plant Nutrition Institute*, (November), p.2.)



4

The Physics of Dewatering

Matt Pyle



Can a simple change make a difference?



Why water first drains twice as fast

Mechanism 1 – Overall bed mass (buoyancy):

- In Method A, gravity pre-settles everything into a thick layer before the valve even opens. In Method B, buoyancy keeps most grounds suspended or floating, so less total material reaches the filter before draw-down completes. Less cake = less resistance.

Mechanism 2 – Particle-size segregation (the pre-coat effect):

- In Method A, coarse and fine particles settle together in an unsorted mass, and fines fill the interstitial gaps between coarse grains – dramatically reducing permeability. Among the particles that do settle in Method B, Stokes' Law dictates that larger particles descend faster (settling velocity proportional to d^2). Fines, with their higher surface-area-to-volume ratio, retain proportionally more entrained air and experience greater drag – so they lag behind. The coarse fraction arrives at the filter first and forms a high-permeability pre-coat.

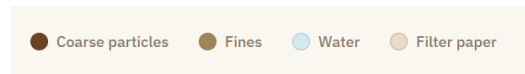
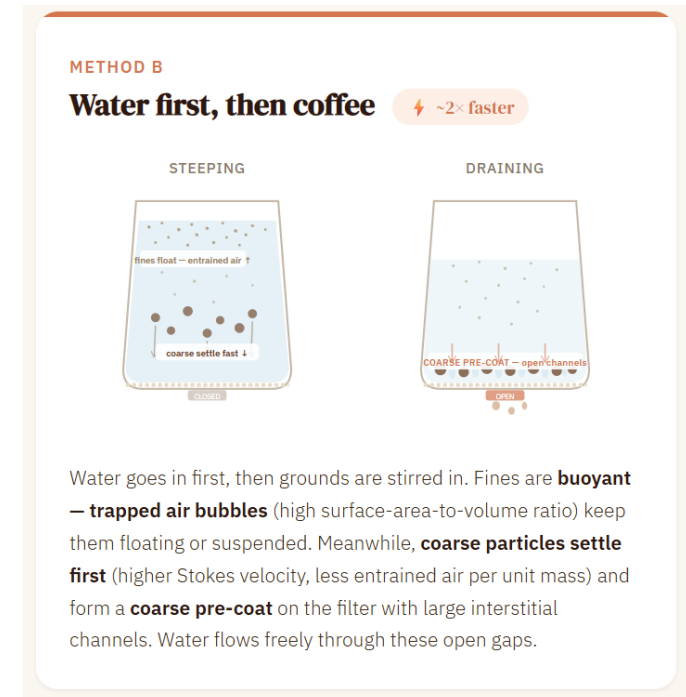
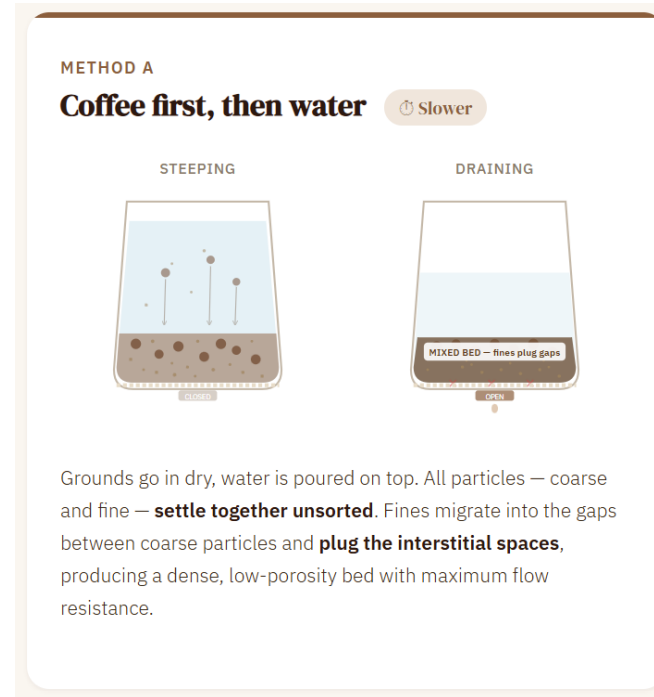

Hydrological Soil Group Classifications

It seems soil classifiers already know what drains quickly!

- A = fast draining
- B = moderate draining
- C = slow draining
- D = very slow draining – mostly runs off

Why don't we optimise the PSD to give optimum dewatering performance in different units?

BE AWARE -> AN EVEN MIX OF CLAY, SILT AND SAND IS CALLED A CLAY LOAM AND IS THE WORST PSD TO DEWATER!!!

... BUT – if you were to separate these into its constituent clays, sand and silt fractions, these coarser fractions dewater much better! Or simply just remove the clay.

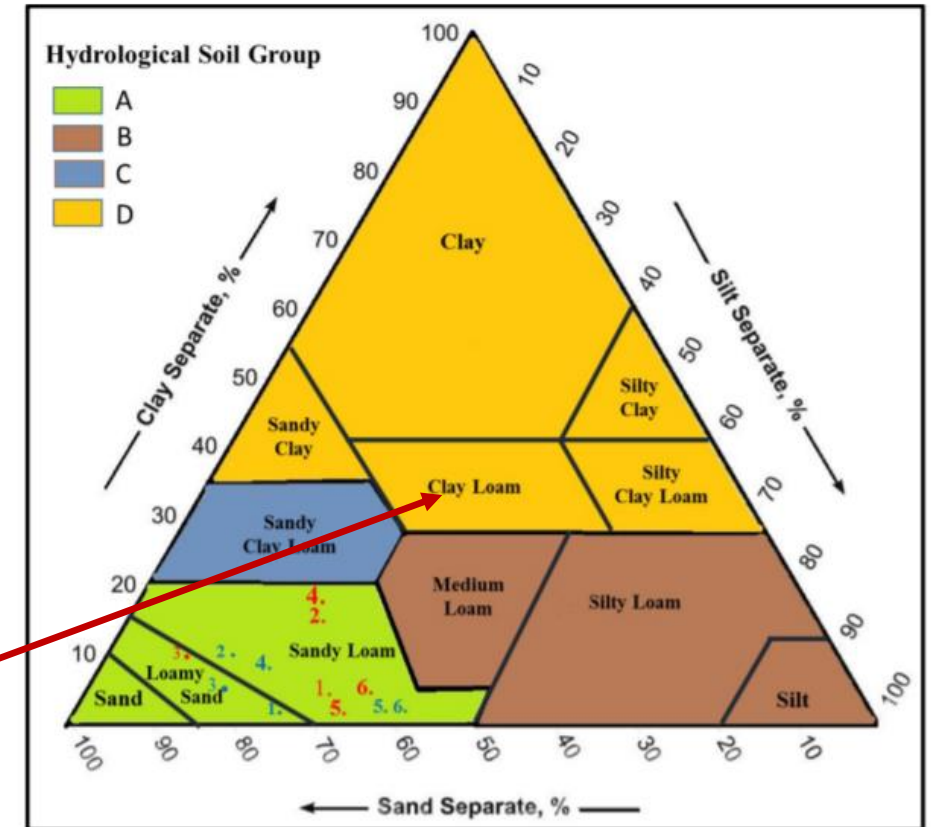

Darcy's Law: The Foundation

Flow through a packed bed of particles:

$$Q = (\kappa \times A \times \Delta P) / (\mu \times L)$$

Q = Flow rate (m³/s)

κ = Permeability (m²)

A = Filter area (m²)

ΔP = Pressure differential (Pa)

μ = Water viscosity (Pa·s)

L = Cake thickness (m)

Engineering levers:

- Increase pressure (ΔP) → vacuum → pressure filtration
- Increase area (A) → more/larger equipment
- Thinner cakes
- Increase permeability (κ) → PSD management (this is the key!)

More cost!



Kozeny-Carman: Why Size Dominates

- Permeability based on porosity (ϵ) and Sauter mean diameter (d_{32})

$$\kappa = \epsilon^3 \times d_{32}^2 / [180 \times (1-\epsilon)^2]$$

Permeability scales with the SQUARE of particle size

Particle Size	Rel. Permeability	Rel. Filtration Time
100 μm	100×	1×
50 μm	25×	4×
20 μm	4×	25×
10 μm	1×	100×
5 μm	0.25×	400×

20× reduction in size → 400× longer filtration!

But – this still grossly over-predicts permeability of clayey soils because many voids in clay contain immobile water, reducing porosity! Can be a further 10 – 100x worse again!



Compressibility

- For compressible filter cakes, specific resistance increases with applied pressure following a power law:

$$\alpha = \alpha_0(\Delta P/\Delta P_0)^n$$

- Where;
 - α_0 = specific resistance at reference pressure ΔP_0 (m/kg)
 - n = compressibility index (dimensionless)

Material Type	Compressibility (n)	Classification
Sand, coarse minerals	0.1 – 0.3	Low
Calcium carbonate	0.19 – 0.50	Low-moderate
Typical mineral tailings	0.4 – 0.8	Moderate
Talc, phyllosilicates	0.47 – 0.70	Moderate-high
Clay-rich materials	0.5 – 0.9	High
Hydroxide sludges	>1.0	Very highly compressible

- What this means: Higher pressure has diminishing (or reduced) returns for compressible cakes.



Particle Shape

- Bourcier et al. (2016) developed a correlation for compressibility based on porosity and particle size variation coefficient:

$$n = (\epsilon/(1-\epsilon))^{\beta} \times (VC)^{\gamma}$$

- Shape-dependent coefficients β and γ ranging from 0.21-0.48 and 0.57-0.76 respectively.

Flat platey particles prevent water mobility

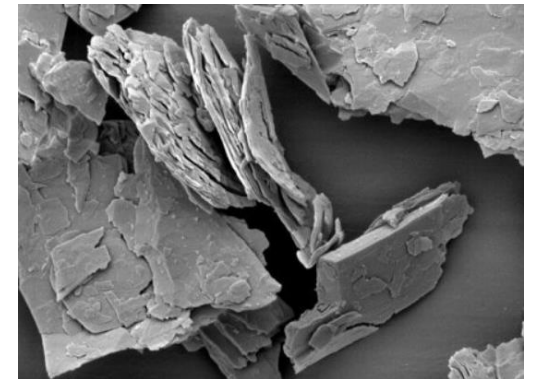

Specific cake resistance values span six orders of magnitude

- Laboratory and industrial measurements provide benchmark α values for engineering calculations:

Material	α at 1 bar (m/kg)	Notes
100 um glass beads	6.4×10^7	Incompressible reference
10 um glass beads	6.4×10^9	100x increase for 10x size reduction
Coarse mineral particles (>100 um)	$10^9 - 10^{10}$	Easy filtration
Fine minerals (20-100 um)	$10^{10} - 10^{11}$	Moderate difficulty
Ultrafine minerals (<20 um)	$10^{11} - 10^{12}$	Difficult filtration
Calcium carbonate (d32 ~7.5 um)	5.9×10^{10}	Well-characterized reference
Talc (similar size to CaCO ₃)	7.4×10^{11}	12x higher due to platelet shape
Kaolin (coarse)	7.1×10^{10}	Non-swelling clay
Iron ore tailings	$10^{11} - 2.3 \times 10^{12}$	Highly variable
Kaolin (fine, clay-rich)	$10^{12} - 10^{13}$	Very difficult
Colloidal clay	6.3×10^{13}	Requires flocculants

- Work by Kinnarinen et al. (2015) on calcium carbonate grinding showed that when the D_{10} size drops below 1 um, specific resistance increases at an extreme rate. Reducing D_{10} from 4 um to 1 um increased α by 7 – 10x. Clays are 1 – 2 um, generally.



Drainage is Highly Anisotropic

Horizontal permability (k_h) typically 5 – 20 x greater than vertical permability. In some, cases >100x for layered deposits

1. Hydraulic segregation
 - Alternating coarse/fine layers
 - Cross-bedding structures
 - Distinct beach (coarse) and slime (fine) zones
2. Particle Orientation During Sedimentation
 - Clay particles rotate to align normal to vertical loading during consolidation
 - This creates preferential horizontal flow paths
 - Effect is strongest for particles with high aspect ratios
3. Consolidation-induced Anisotropy
 - Vertical compression preferentially closes vertical pores
 - Horizontal pre channels remain more open
 - Particle contacts shift from point-to-point toward face-to-face contact in the vertical direction

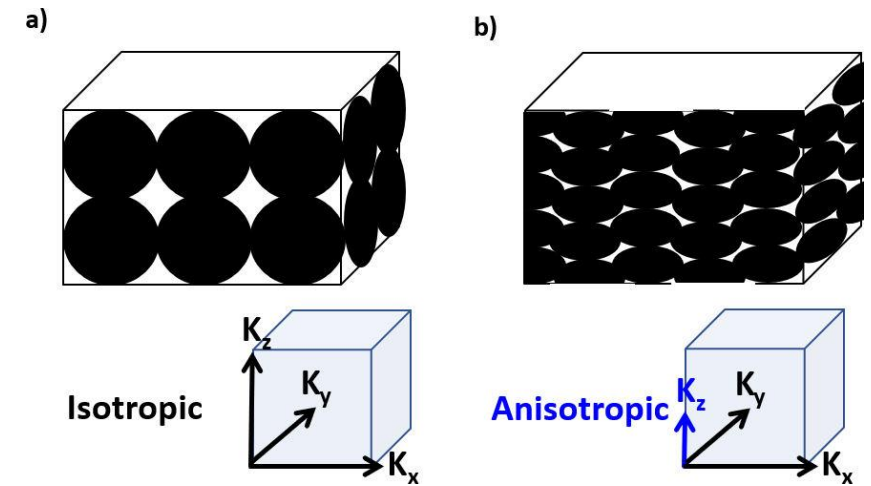

The rate of dewatering could be significantly increased by choosing drainage to be perpendicular to the direction of applied compressive force.



The Core Problem

Why is tailings dewatering expensive?

- A feed containing 40% fines forces the entire filtration system to operate at the resistance of the finest fraction – even though 60% of the material could be dewatered with much simpler equipment



The Bimodal Distribution Problem

- Let's consider that our tailings PSD is bimodal* (coarse gangue + fine clays/weathered minerals)

Example: 65% coarse + 35% fines

Coarse only:	$\kappa \approx 10^{-10} \text{ m}^2$	(fast)
Fines only:	$\kappa \approx 10^{-13} \text{ m}^2$	(slow)
Mixed:	$\kappa \approx 10^{-12} \text{ m}^2$	(fines dominate!)

Critical Fines Threshold

~25-30%

Above this threshold, fines form a continuous matrix that controls permeability

Implication: Above ~25% fines, adding more coarse material provides minimal benefit. The effective d_{32} remains controlled by the fine fraction.

*While this discussion uses 'bimodal' framing for clarity, the principles apply to any distribution with significant fine content. The key parameters—fines fraction, d_{32} , and specific cake resistance—characterize filtration behaviour regardless of whether the PSD has bimodal peaks or is continuous.



Filtration Time (lab based CaCO₃)¹

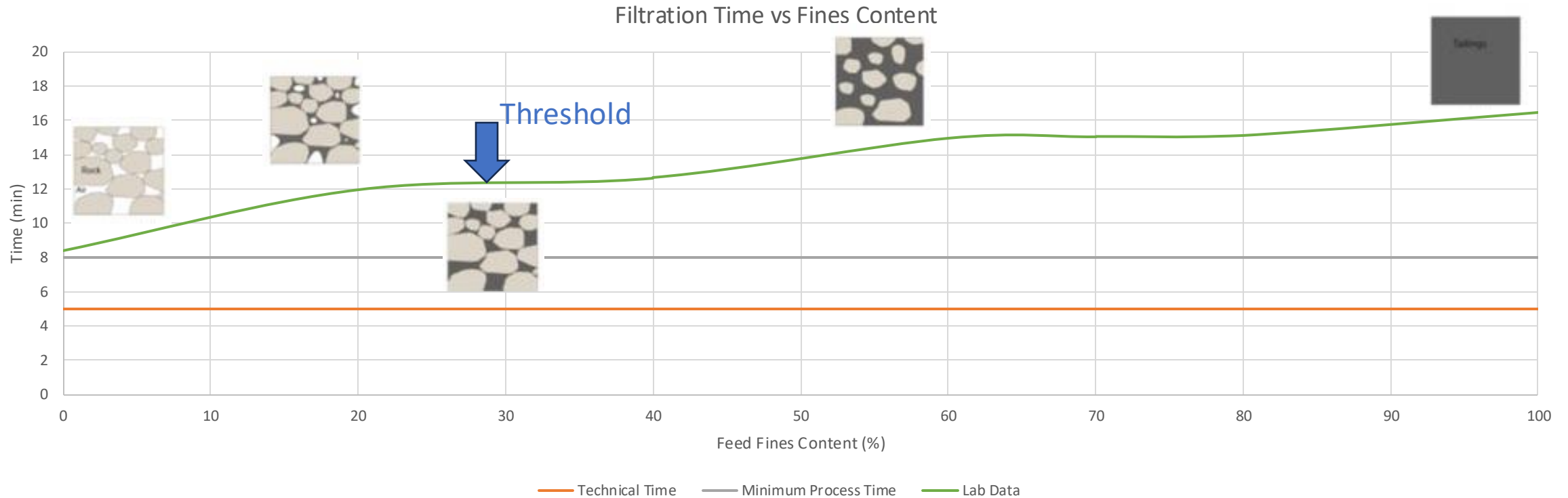

- Take a pressure filter with 5 minutes technical time and minimum 3 minute 'minimum process' time (8 minutes total).
- Filtration time vs %fines is not linear!

1. Hassan, S., Ekanayake, N.I.K., Scales, P.J., Batterham, R.J. and Stickland, A.D. (2025) 'Quantifying the effect of ultra-fine particles on dewatering performance in bimodal suspensions', Powder Technology, 458, article number 120986.



Thickener Underflow Rheology

- Rheology driver – colloidal behaviour, network structures
- Increases yield stress at given slurry density
 - Reduces thickener underflow density for given thickener yield stress limit

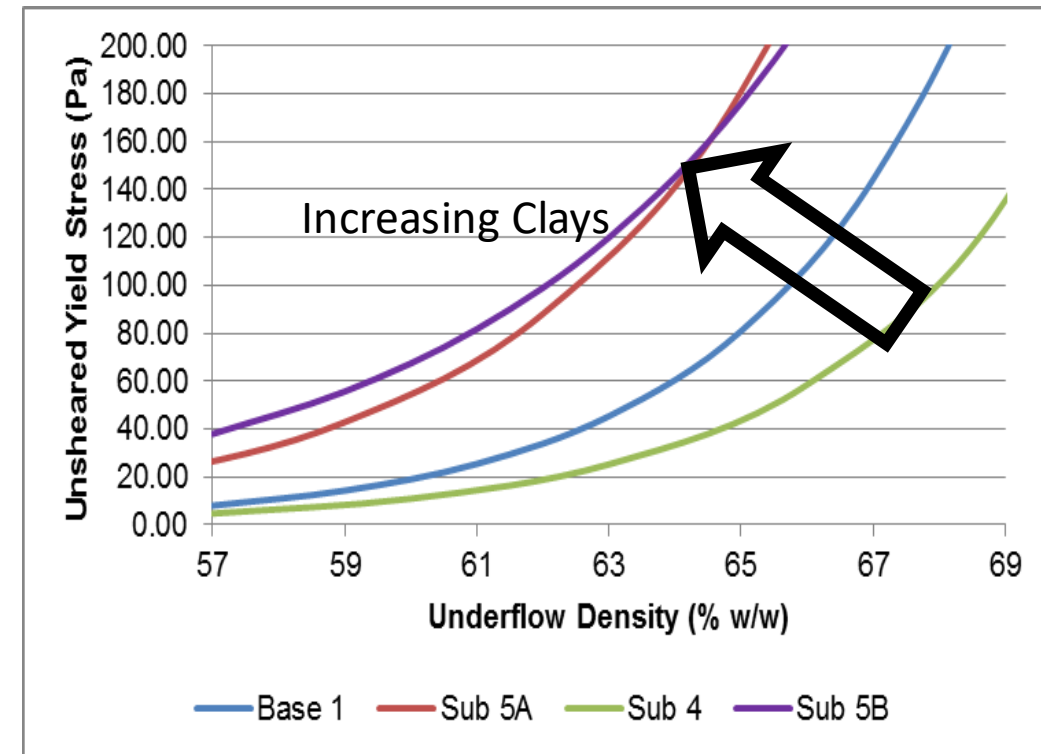
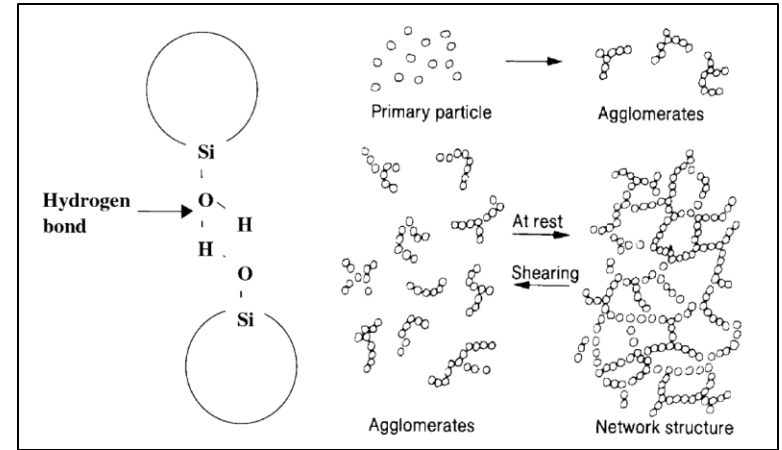

Filtration

- % passing 10 micron can be a useful benchmark for thickening and filter throughputs
- Impacted by clay content and mineralogy

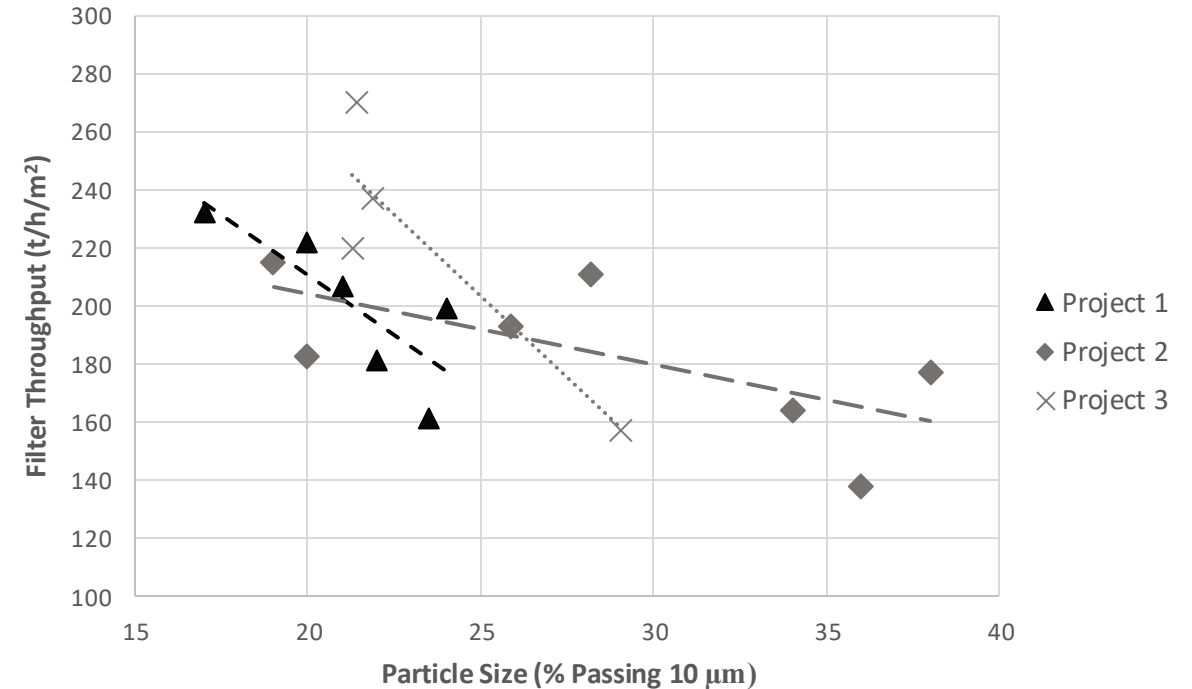

Filtration Proxies

Not all clays are created equal;

- Thickener and filtration results plotted vs CEC + 0.2 x Mg clay content
- Thickener underflow density reduces with increasing clay content
- Filter throughput reduces with increasing clay content
 - High clay samples which were dried and reconstituted with tap water do not exhibit drop in filtration rate at higher clay contents
 - Based on FFP-3512 74/74

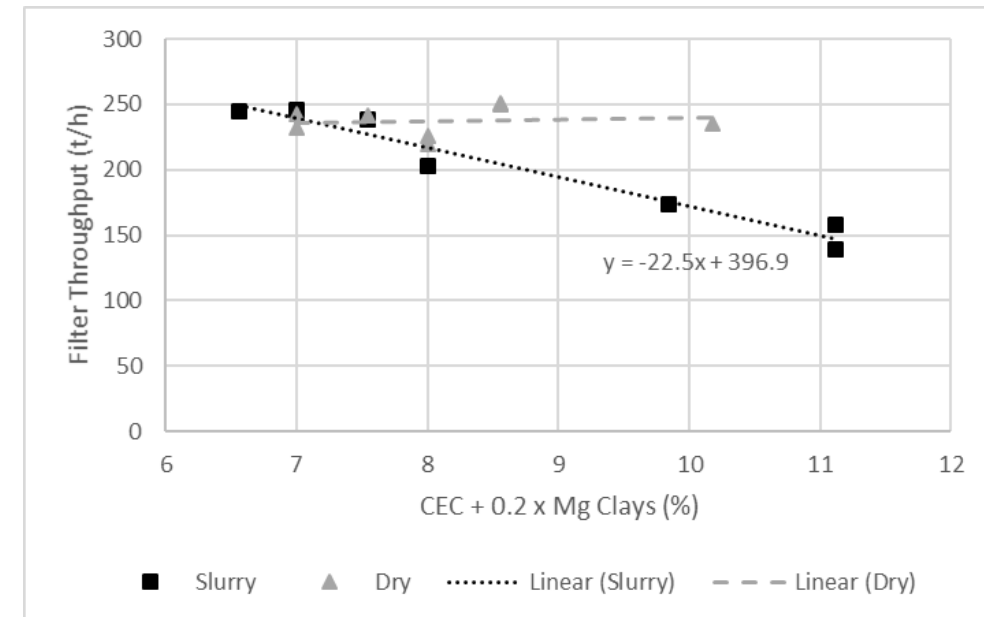
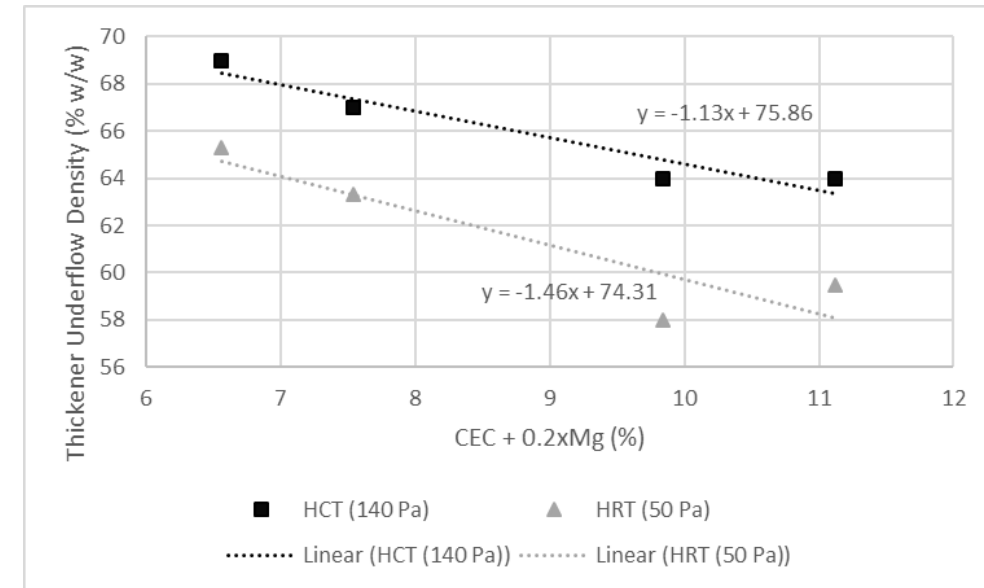

Cost fundamentals of dewatering

- Huge difference in capital costs, driven by size fraction i.e. for example
 - Pressure filters for 'clay', vs
 - Vacuum filters for 'silt', vs
 - Dewatering screens for 'sand'

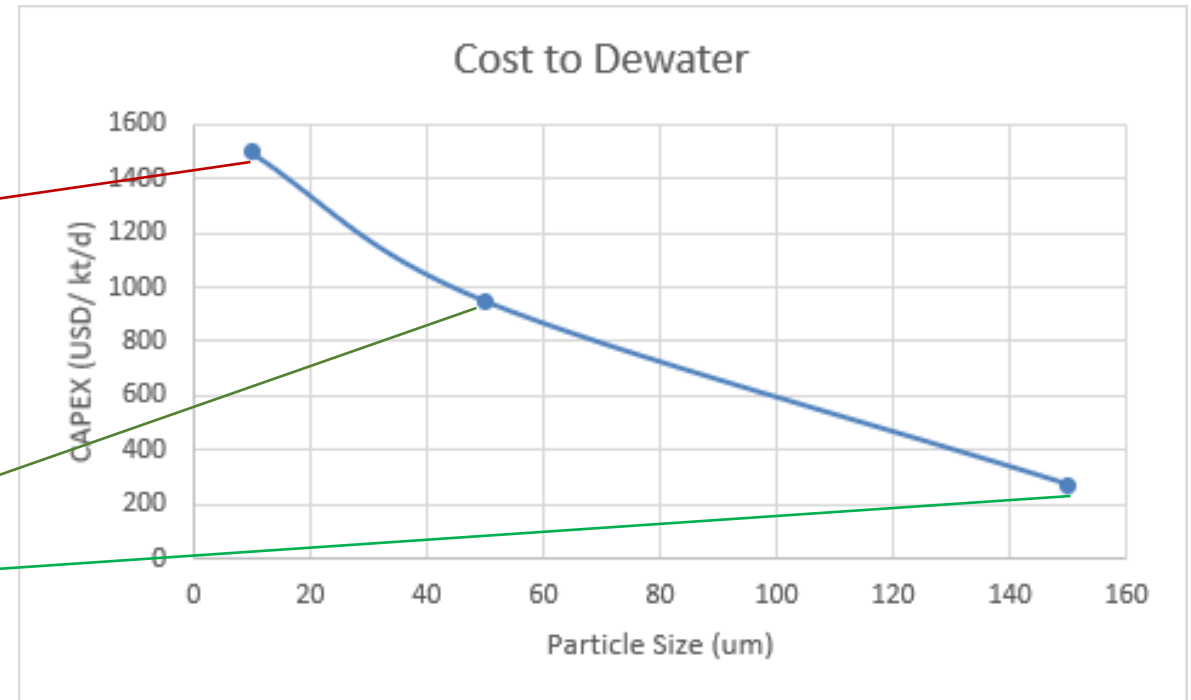
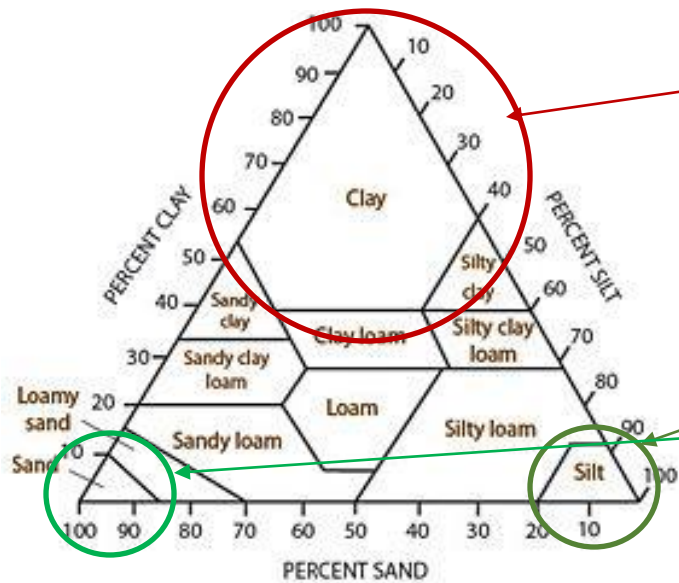

Typical size distributions that can be generated out of tailings

Multiple approaches exist in the industry already:

- Split size fraction dewatering
- Coarse material cyclone to wall
- Deslimed silt – onto high-g (high frequency) dewatering screen
- Fines in a centrifuge

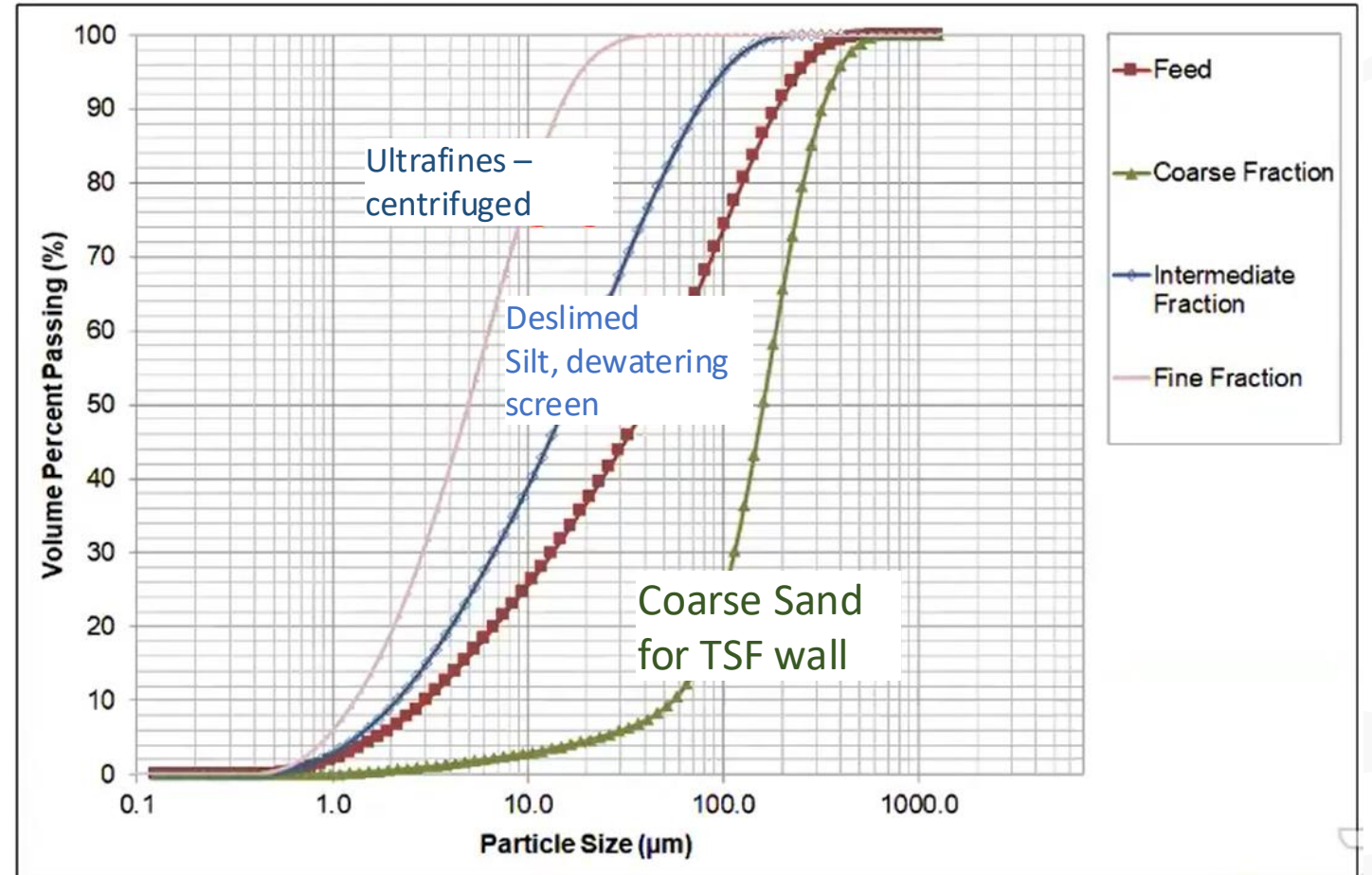

Ultrafines Removal Strategy (Project 1)

The -10 μm fraction often controls filterability more than bulk PSD

Project 1

Feed: $P_{80} = 38 \mu\text{m}$
(conventionally "too fine" for HBF)
Solution: Remove -10 μm ultrafines
Result: HBF viable!

Achieved Throughput

1,000

kg/m²·h on HBF

(vs 300-500 typical for fine tailings)

Total plant tailings, 38 μm P80,
Vacuum filter, ~250 kg/m²·h, 24% w/w moisture



Deslimed (removing -10 μm), ~48 μm P80,
Vacuum filter, ~1,000 kg/m²·h, 17% w/w moisture



Implication: A $P_{80} = 38 \mu\text{m}$ tailings would conventionally require pressure filtration. By targeting only the ultrafine tail, the effective d_{32} increases enough to enable vacuum filtration—avoiding expensive equipment for the bulk stream.



Layered HBF Pre-coat (Chuquicamata Approach)

Both streams dewater together ON THE BELT

1. Coarse (cyclone U/F) placed first -> forms pre-coat layer
2. Fines (cyclone O/F) placed on top
3. Fines drain through high-permeability coarse layer
4. Combined cake discharges together (1-3 min residence)

Key Physics

Permeability ratio: 100-1000×
Pre-coat benefit: 30-80% α reduction
Requirement: >50× perm contrast

Benefits

CAPEX: ~40% of pressure filter
Single unit, combined discharge
Moisture: 20-25% (acceptable)

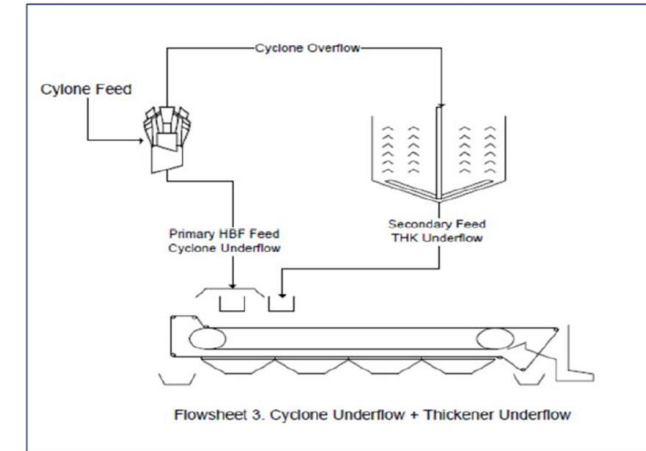

Electrophoresis Slide



- In full scale trials, electrokinetic geosynthetic (EKG) materials retrofitted to belt filter presses have increased the solids contents of sewage cake from ~20% dry solids to ~31% dry solids and diamond mine tailings from ~62% dry solids to ~75 dry solids%.
- The former resulted in a 40% volume reduction and prospective cost savings to water companies of £132,000 per belt filter press machine per annum.

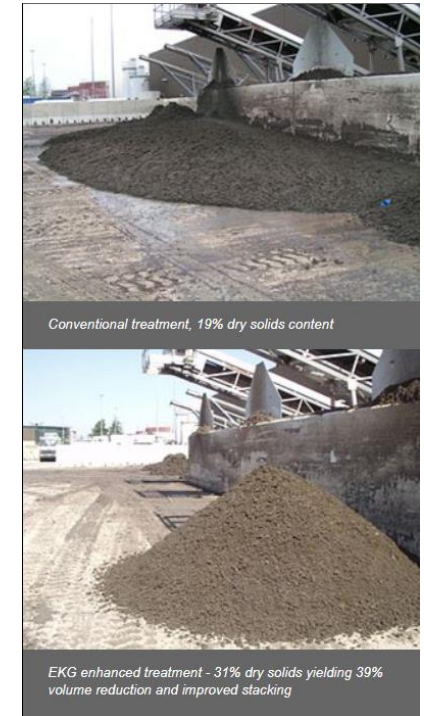
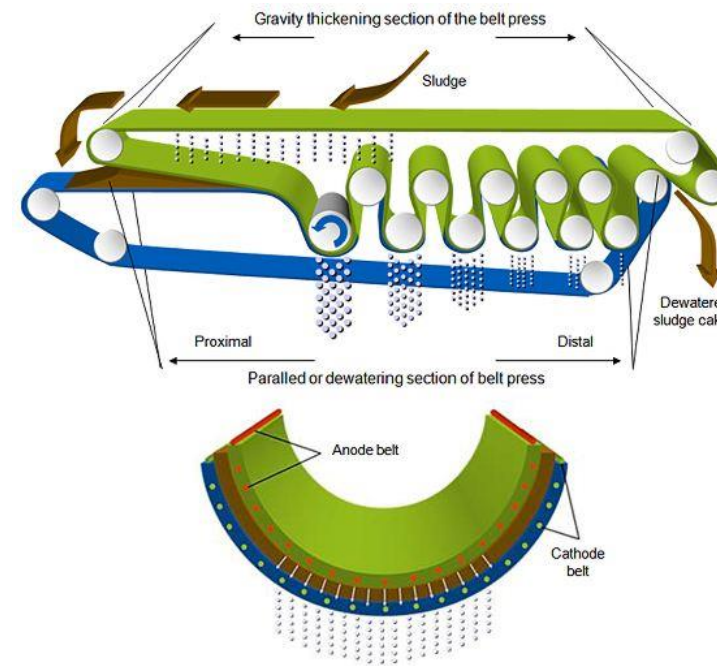

High Throughput Surface Paste

- Paste methods have historically failed due to issues with paste thickeners (rheology) – hence have a bad reputation.
- Multiple (i.e. ~10) sites have limited tailings capacity due to poorer than expected thickening performance and not achieving underflow density
- Most TSFs store ~50% by volume water
- Why not blend our “new” HBF product with thickener underflow like an underground paste plant (in a pug mixer)?
- Locate it close to the deposition point to minimise pumping requirements
- Match the deposition slope to the topography and voila – no TSF wall required
- Precedents exist at >50 CTD and DVD operations (refer following slide), plus sites like Centinela

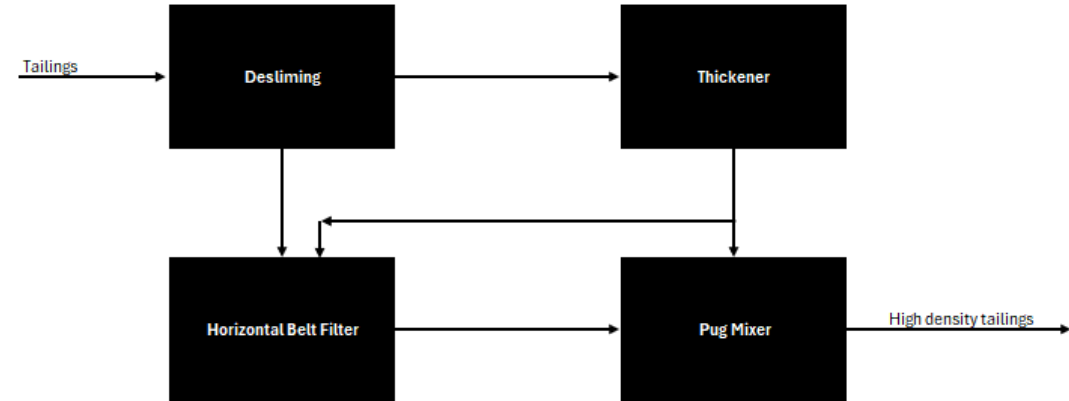

Excess sand for TSF wall construction

- Depending on the project, maybe we still produce excess sand – for TSF wall construction and containing our high-density surface paste?

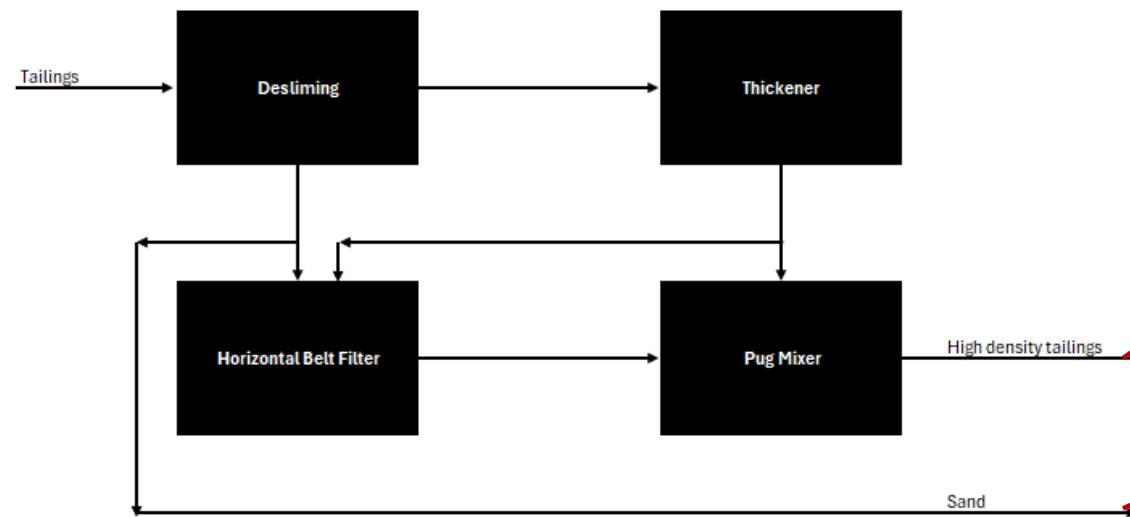

Dewatering Flowsheet for Dry Stacked Tailings

- If higher densities are required again, if the tailings is coarse enough, sand can be dewatered to a lower moisture and mixed back in.
- This approach can achieve similar moistures to filtered tailings, **but at approximately half the capital and operating cost**
- Sand and silt dewatering is cheap, slimes dewatering is achieved in a centrifuge. Centrifuge OPEX can be high given high flocc consumption, however installed CAPEX is lower than filters when treating ultrafines only
- All unit operations are 'continuous' further saving on storage tanks.

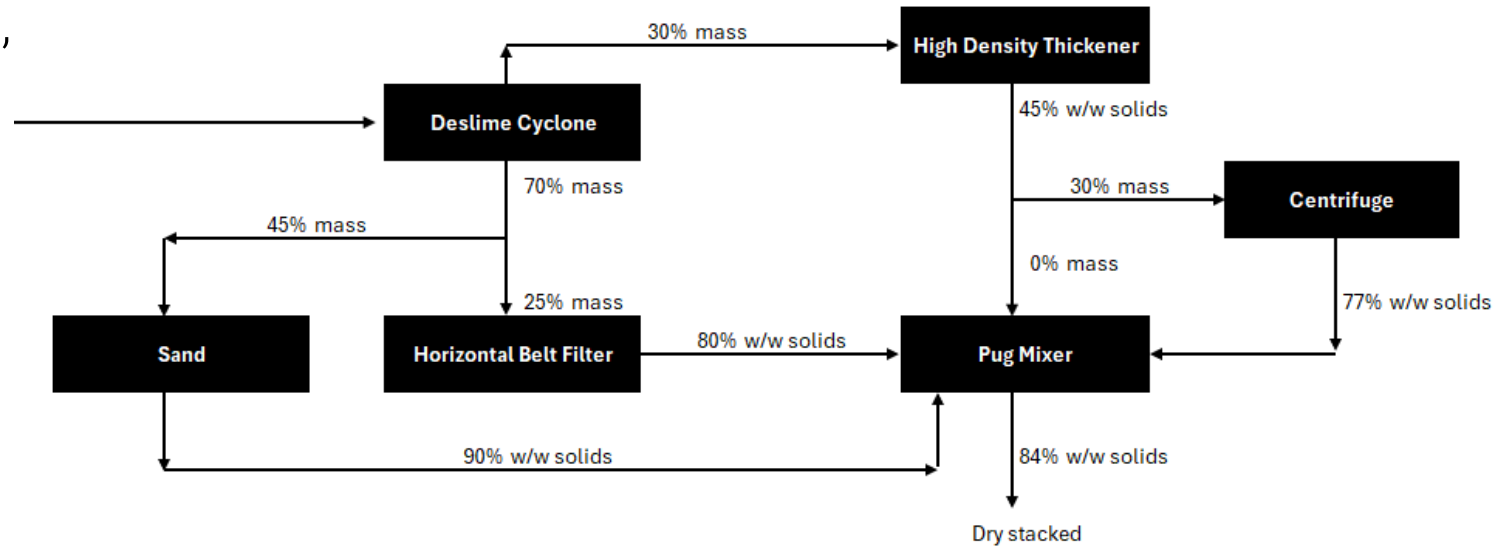

New Approaches

- HBF with vibrating roller compactors (Viper);
 - Increase throughput by ~30% at same moisture, or
 - Reduce moisture by ~3%
 - Lower cost dewatering
- Combined waste rock and filtered tailings and sand (ala EcoTails)
- Larger tailings filters (-~15 – 20% TICs)
- Dewater sand directly from HydroFloat™ tails with screens and stack with mechanical equipment



Wet -centrifuged fine gold tailings – somewhere between pumpable and conveyable yet flowable!!!



Dewatering – with or without CPF (example 100 kt/d)

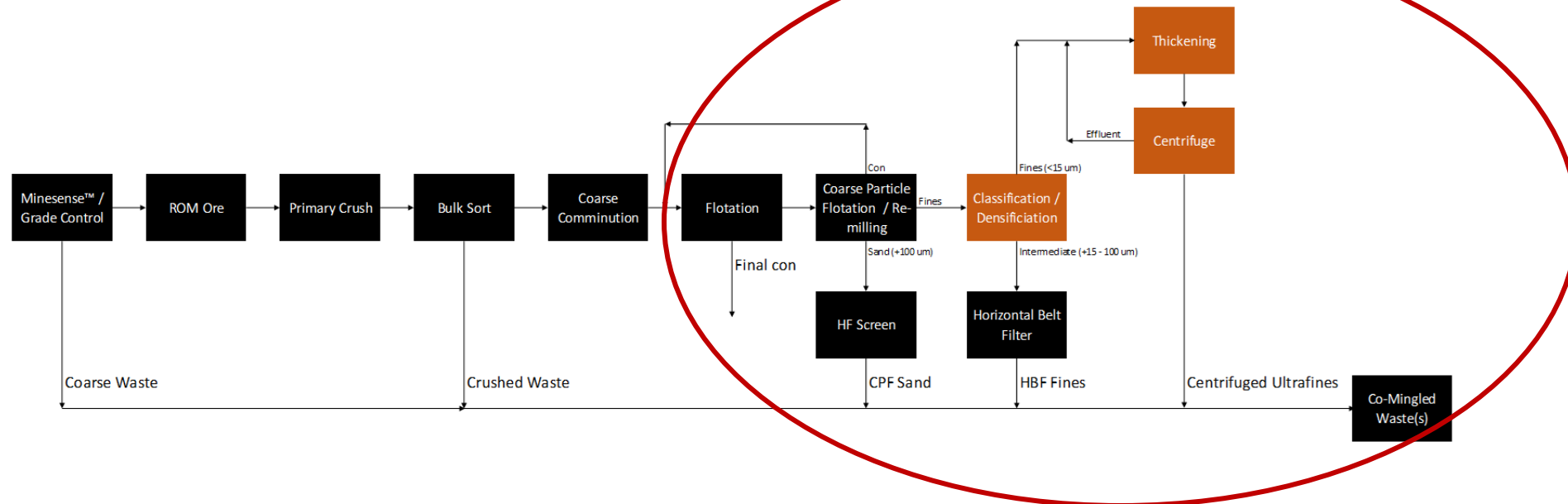

	Pressure Filters	Combination HF + HBF + CF	Comments
Moisture (% w/w)	15.5	16	Similar moisture
CAPEX (USD M)	200	90	Capex is halved or less
OPEX (USD M/y)	100	56	Opex is about half – subject to flocculant consumption

Assumes approximately half of the material is available in a 'sand' fraction (+100 um)



Layered Co-Disposal (Anglo American HDS)

Process

1. Coarse → HBF → ~17% moisture
2. Fines → Thickener → 55-65% solids
3. Layer in TSF, consolidate in-situ
4. Drainage via coarse layer (15-60 days)

Key Physics: Two-way drainage

Drainage path halved → 4× faster consolidation

$$t_{90} = 0.848 \times (H/2)^2 / c_v$$

No pressure filter for fines!

Comparison: HBF Pre-coat vs Layered HDS

Aspect	HBF Pre-coat	Layered HDS
Time scale	1-3 minutes	15-60 days
Fines equipment	None (same belt)	Thickener only
CAPEX vs PF	~40%	~55%



TSF Drainage

- Exploit Radial/Horizontal Drainage
 - Prefabricated Vertical Drains
- Vacuum through horizontal drainage network
- Adaptations to pressure filters?
- Adaptation to vacuum filters?



Anglo American Hydraulic Dewatered Stack Concept



5

Tailings Storage

Campbell Haines



Recap: Where do our tailings come from?



VISUALIZING THE SIZE OF

THE WORLD'S MINE TAILINGS

Tailings are what is left over after economic minerals are separated from mined rock. They comprise ground rock material and liquid waste from mineral processing plants.

They are fine particles mixed with water, forming a slurry that is stored in ponds or dams. The volume of tailings and their storage pose a risk to the natural and human environment.

The Global Tailings Review estimates that the total number active, inactive and closed storage facilities is **8,500** with **217km³** of tailings, enough to fill a cube 6km high.



Annual tailings growth **12.3 km³**

GLOBAL TAILINGS

Height

6 km

Volume

217.3 km³

Weight

282.5 billion tonnes

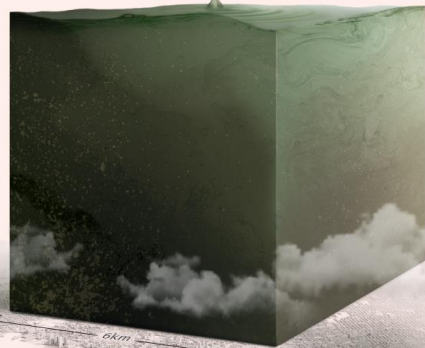

Some metals produce more tailings than others. The type, quality, quantity and production decisions of mineral deposits determine the amount of tailings waste a specific mine produces.

CONTRIBUTION TO GLOBAL TAILINGS, BY COMMODITY

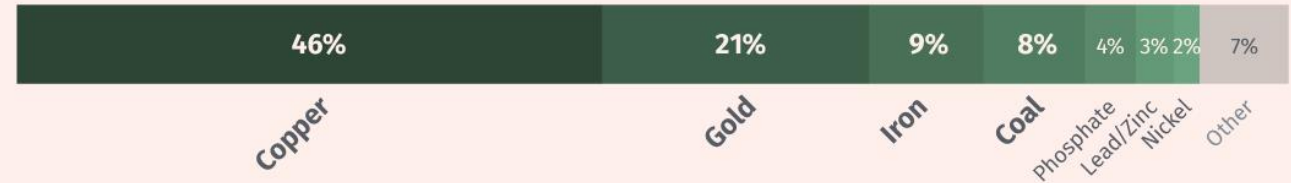

The volume of waste material produced per unit of commodity is increasing due to declining ore grade. Tailings are only going to grow as populations grow and grades decline.

Source: Global Tailings Review, ICMM, UNEP, PRI

Note: Tailing facility estimates come from using the reported number of facilities projected to global commodity production using USGS mineral commodity production estimates.

ELEMENTS

The Earth's natural resources power our everyday lives. VC Elements breaks down the building blocks of the universe.

We live in a material world.



How safe is our dams factor of safety?

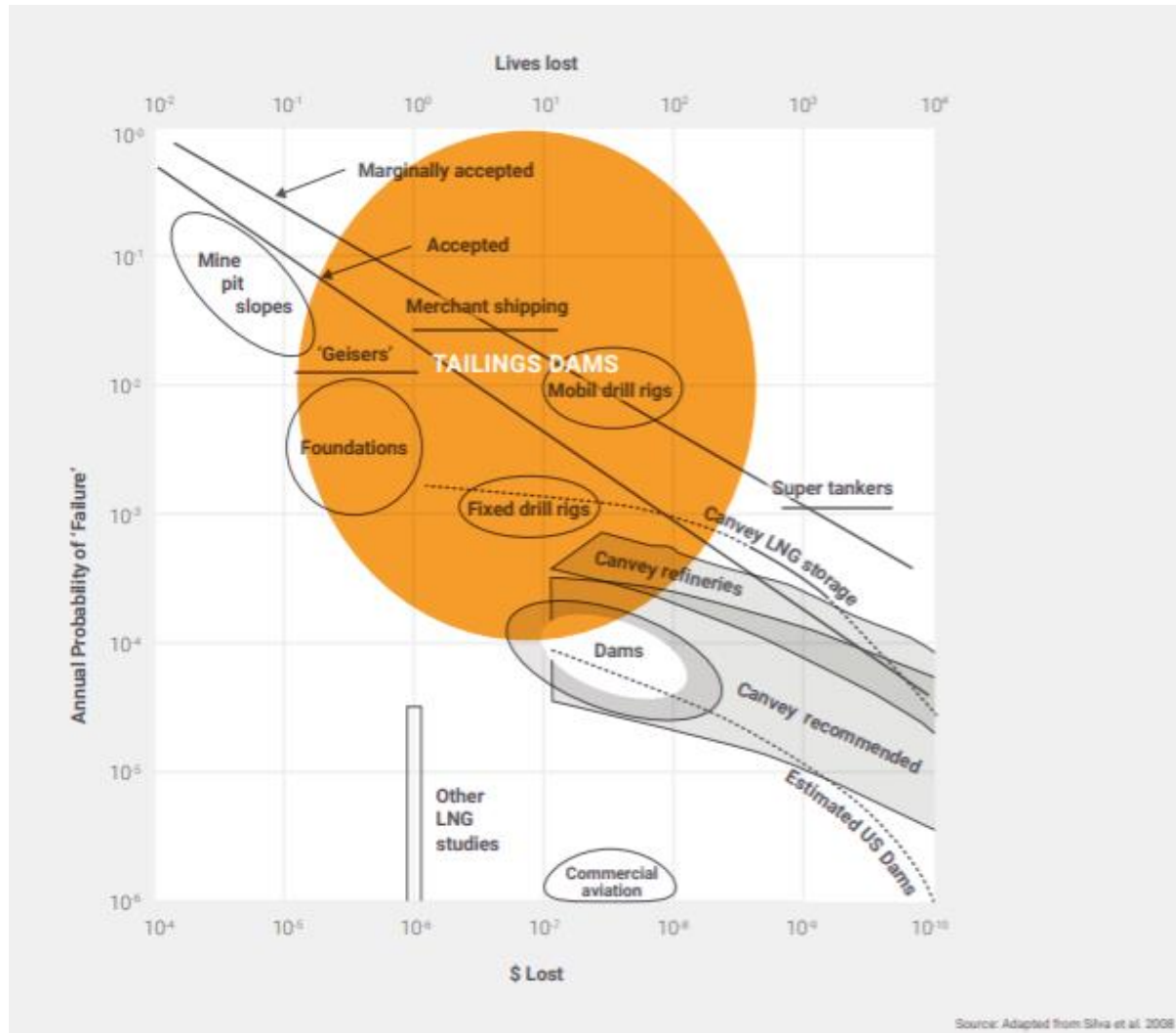

- While most dam's do not fail, the probability of failure across industry based on actual rates of failure is beyond what society deems acceptable. 'it won't happen to me', 'it won't happen here'
- Achieving physical stability of tailings via dewatering (how dry is possible, and how dry is dry enough) must be balanced against the need to ensure geochemical stability
- What drives the consequence of failure in tailings dams? Solids or Water? Compare Dams vs Mine pit slope.
- Probability of failure in and of itself is not critical if the consequences are manageable. Pit slope failure is common, the consequence is often minimal.



Key Focus Questions

- What are the closure implications different tailings storage facility types?
- What sort of tailings streams could we produce?
- What is the value of water to the project? (Dry climate vs wet climate)
- How does the topography and project factors influence the type of tailings storage options?
- What else can we do to minimise the quantity of tailings? I.e. pre-concentration?
- What are the implications of the proposed design(s) water content in regards to dam runout assessment, future resource conversion, future production expansion?



Tailings Deposition Strategies

“Conventional” waste approach:

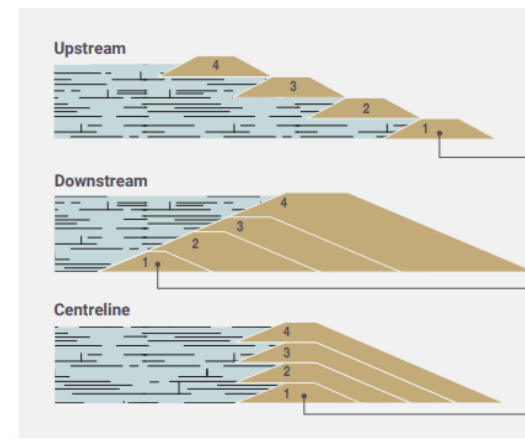
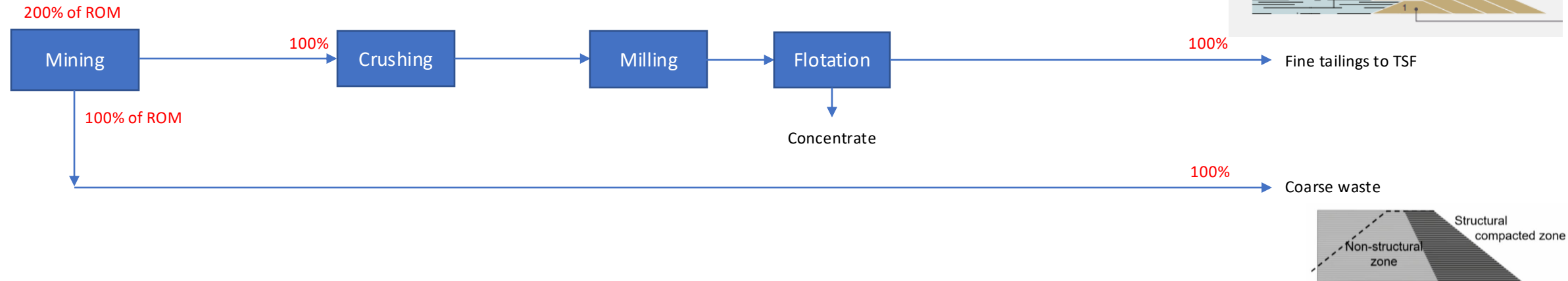

*Assuming 2:1 strip ratio



The Tailings Continuum

Linking Placement to Embankment stability

inefficient water & process chemical recovery
Centrifugal pumps sufficient
Extensive water management
Containment required
High runoff & potential seepage
Rehabilitation difficult (soft & wet)
Low CapEx and OpEx, but high rehab. cost

Tailings slurry
(typically segregating)

Slurry-like: No particle/particle interaction, saturated, no effective stress

Clay mineral-rich tailings stuck here

Improved water & process chemical recovery
Positive displacement &/or diaphragm pumps
Discharge management required (steeper beach)
Reduced water management
Some containment required
Some runoff & seepage potential
Rehabilitation difficult (soft & wet)
High CapEx and OpEx, and high rehab. cost

Thickened tailings
(dewatered, ideally non-segregating)

Paste tailings
(Dewatered, ideally non-bleeding)

Pumpable

Efficient water & process chemical recovery
Transportable by truck or conveyor
Minimal water management
Minimal containment required
Negligible seepage losses
Progressive rehab. possible
Stable tailings mass
Very high CapEx and OpEx, but low rehab. cost

'Wet' filter cake
(near-saturated)

'Dry' filter cake
(85 to 70% saturated)

Non-pumpable

Soil-like: Particle/particle interaction, effective stresses and suction, shear strength

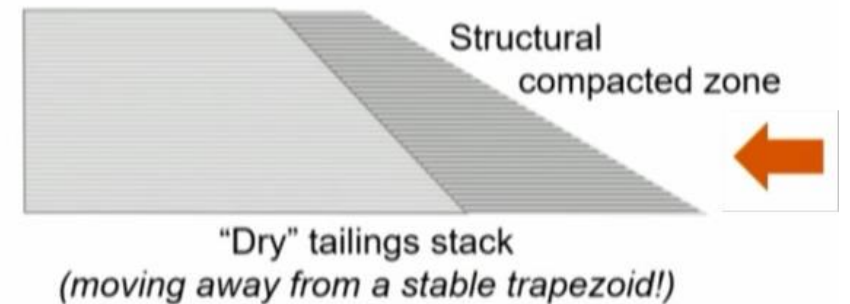
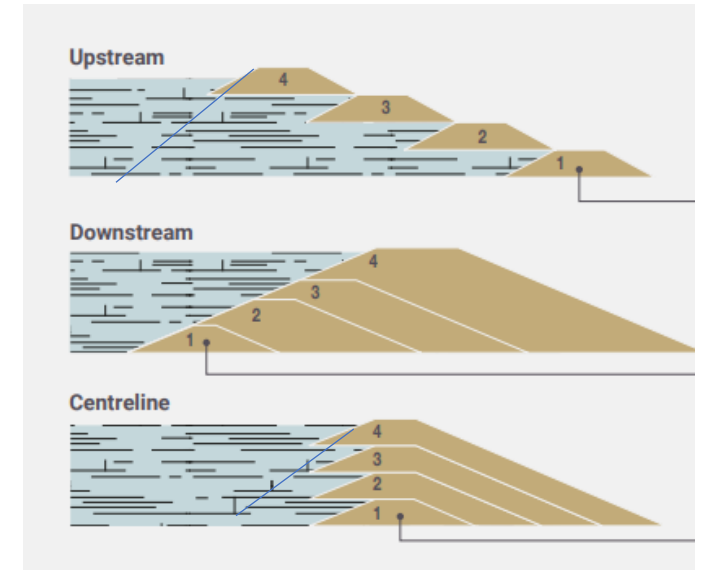

Source: After Williams 2017; adapted from Davies and Rice 2004



Why not just filter tailings?

- Even if we filter tailings, they are still wet.
- Achieving sufficient filtration to enable compaction is difficult, more so for fine-grained wet clay mineral-rich tailings
- Evaporation is required (OK for some climates, not for others) – but introduces climate risk
- Footprint is required for evaporation
- Resaturation can occur
- This means tailings engineers will still place dry tailings within a buttress....
With associated costs....

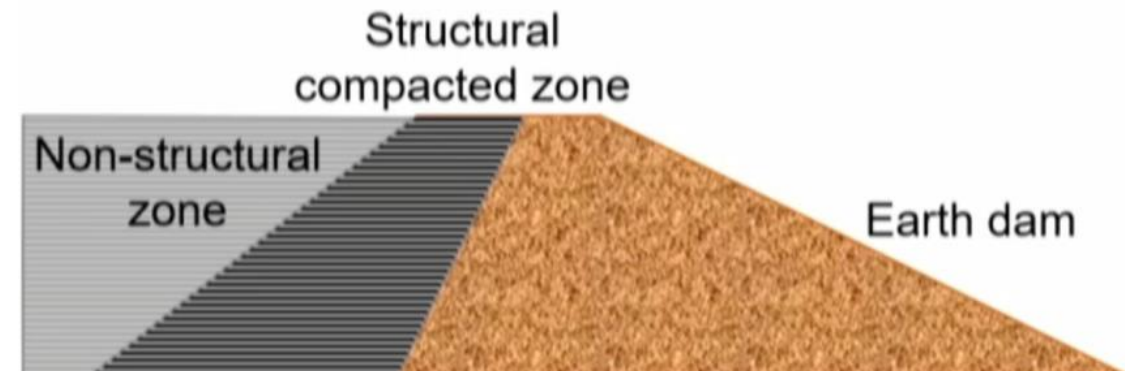
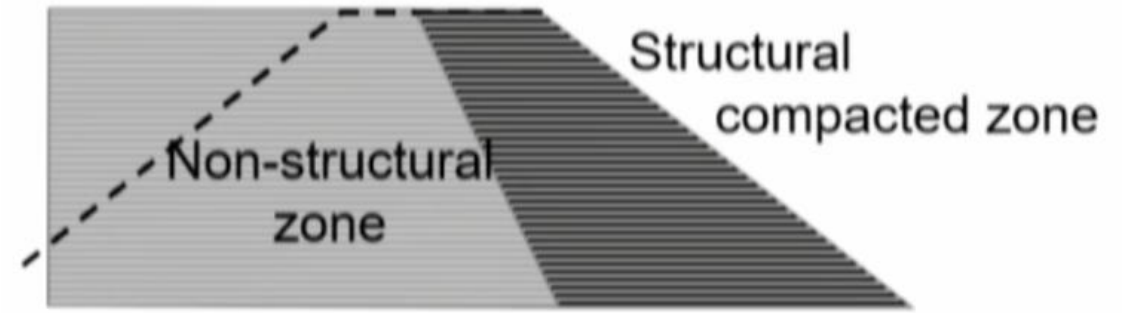

Classifying Tailings: Solids Component Storage

Metallurgical Engineers "language"
 Slurry Solids Conc. (%m) Vs. Yield Stress (Pa)

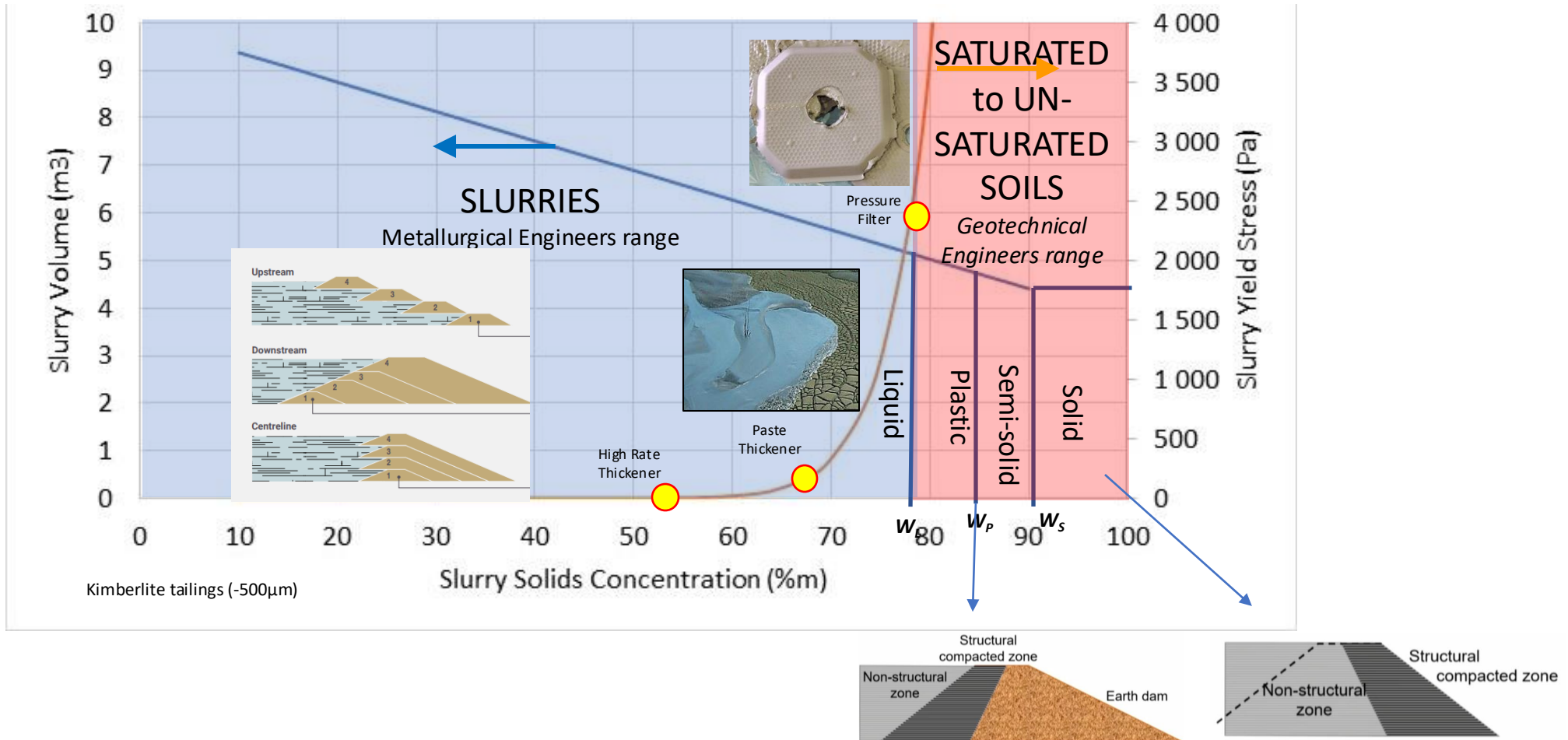

Storage Examples - Arid climate (Chilean)

Conventional solution: BHP Escondida

- Tails thickened to ~55%w/w. Slurry transport to large facility, 5km water reclaim distance to central. Project topographical influence (basin fill)
- Low Water Recovery. High cost water supply (sea water, 75% of makeup volume @ upto 4 US\$/m³). Makeup estimate of +0.7 m³/t

Novel Solution: Capstone Copper Mantos Blancos

- Sand Slimes Splitting Tailings Thickening (SSSTT).
- Sand dewatered at process plant. transported and stacked via truck/dozer.
- Reduced wet volumes hydraulically transported to small dam size and improved water makeup (0.3 m³/t)

Novel Solution: Sierra Gorda

- Tails thickened to +65%w/w. Slurry transport to large flat facility (5km length) with minimal embankment. Cell deposition for improved water management.
- Low-moderate water recovery (0.45 – 0.5 m³/t. High stability, low consequence. Utilised project factors to minimise dam embankment size, failure consequence and cost

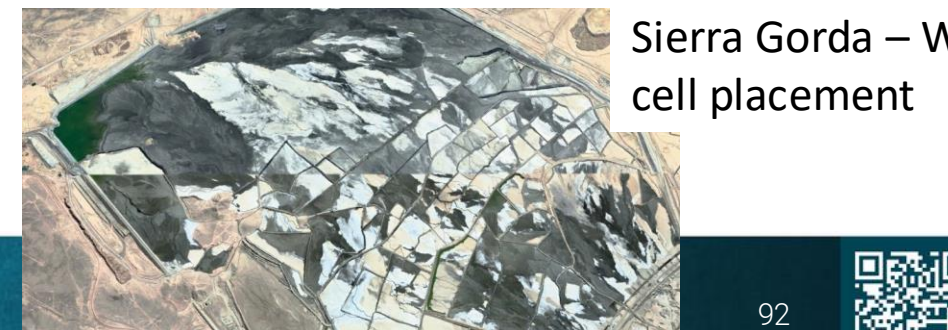
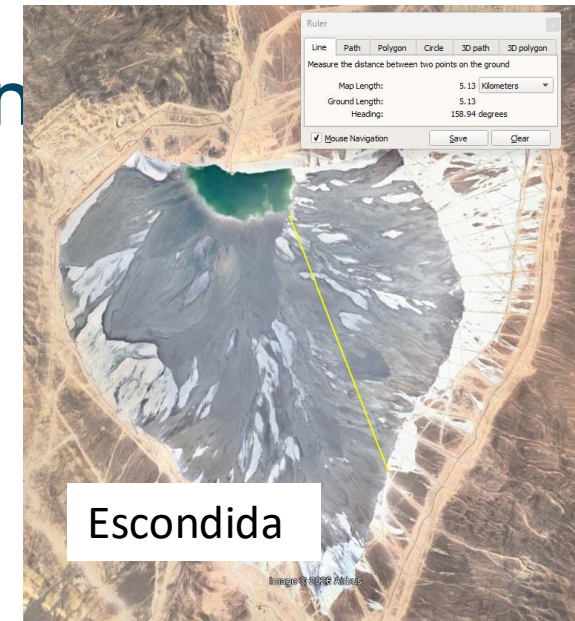

Tailings Deposition Strategies

“Conventional” waste approach:

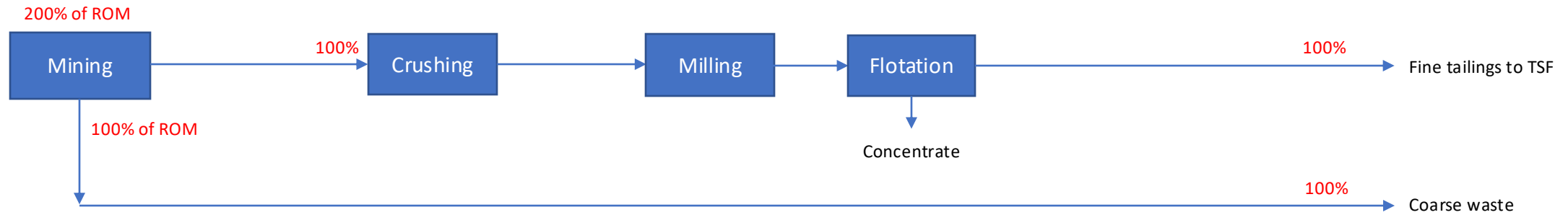

“Next Generation” waste approach, for same mining production:

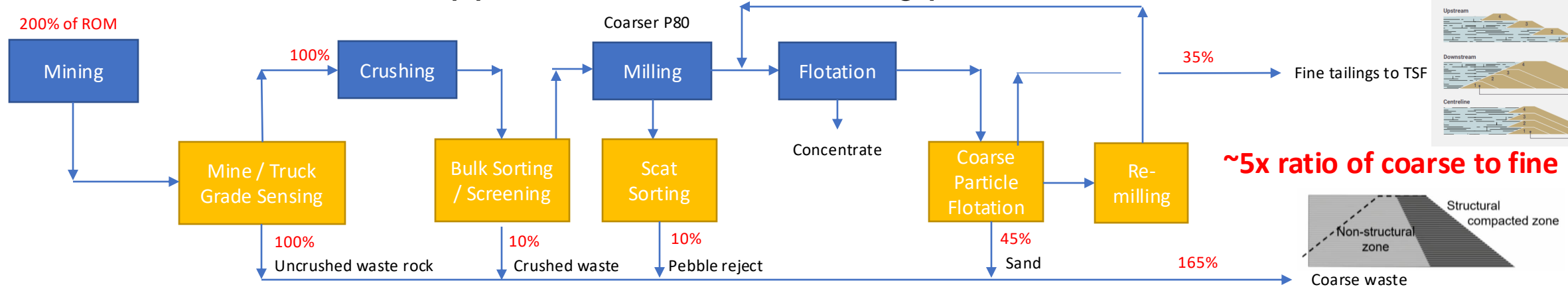

*Assuming 2:1 strip ratio



Trick # – Separate and segregate to minimise the wet volume contained

- Reduced tailings embankment heights => lower cost, simpler permitting
- Reduce runout consequence => simpler permitting and management
- Improve factor of safety to embankment => excess sand/waste for embankment buttressing
- Improve water recovery over LOM as less reliance on tailings dam. Escape the later stage water recovery trap with slowing rate of rise.
- What could each separation/segregation stage be worth?

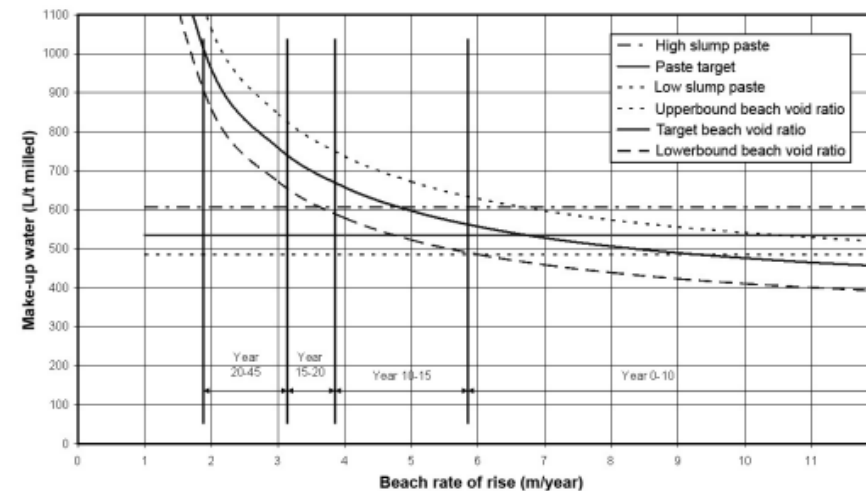

Next Generation Tailings Deposition Strategies

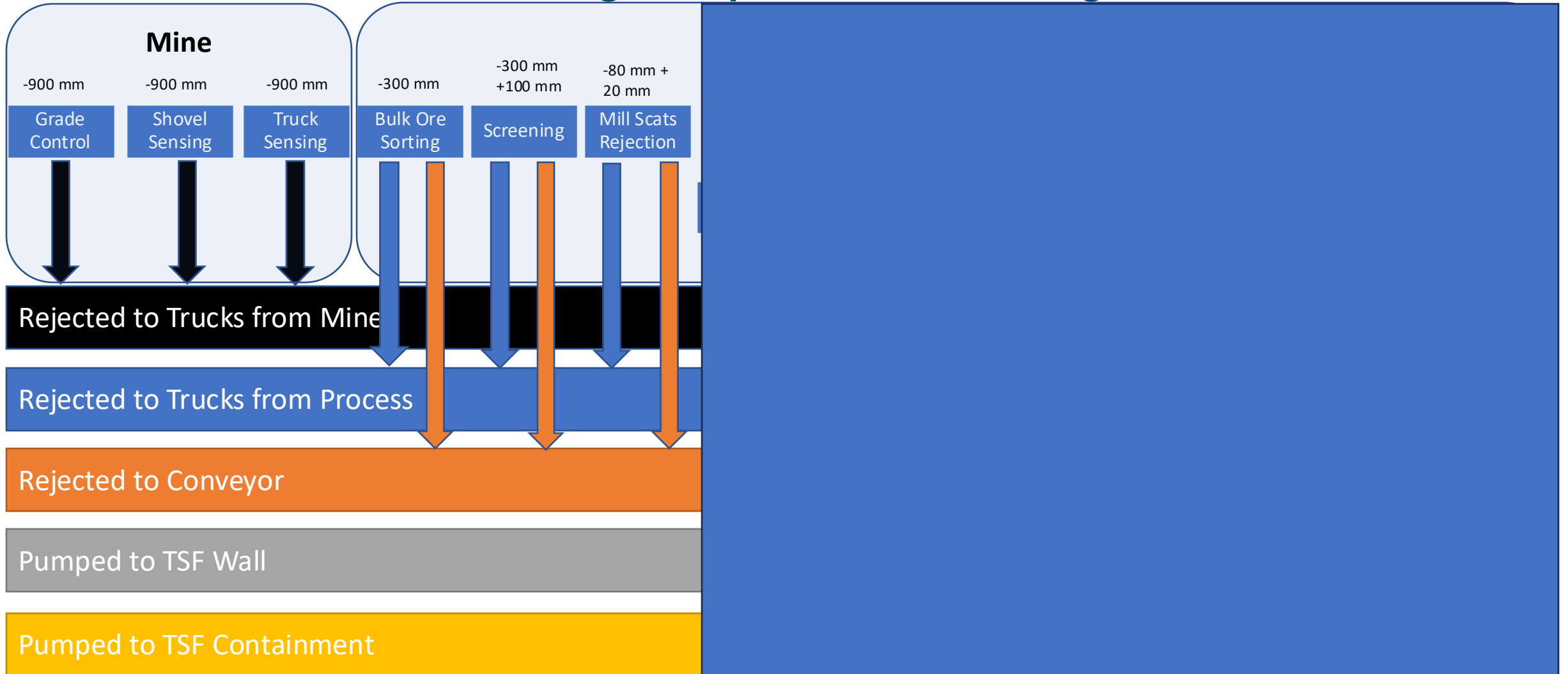

Tailings Deposition Strategies

“Conventional” waste approach:

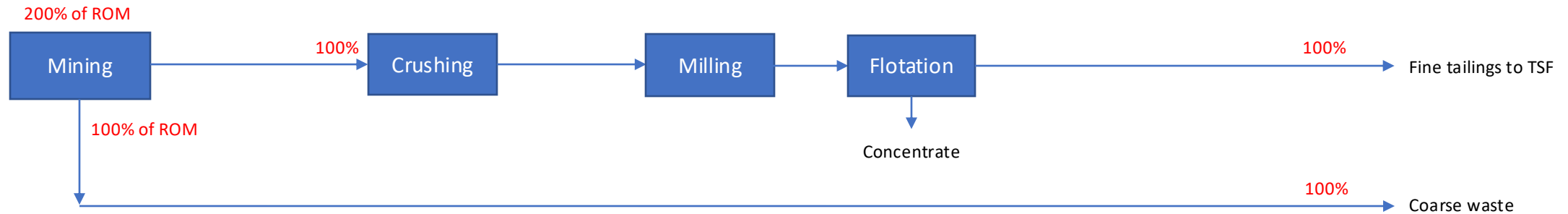

“Next Generation” waste approach, for same mining production:

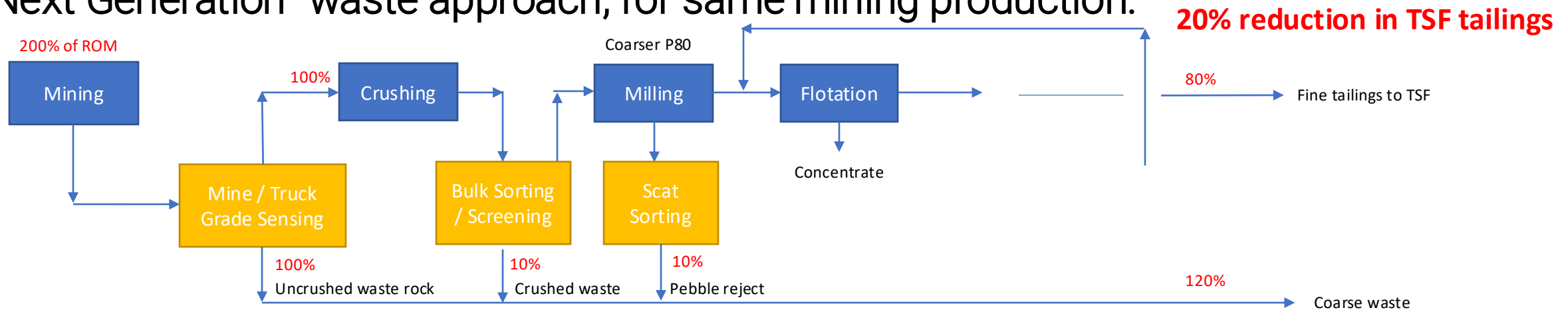

*Assuming 2:1 strip ratio



Sand Separation

- From CPF facility or separated from final tailings

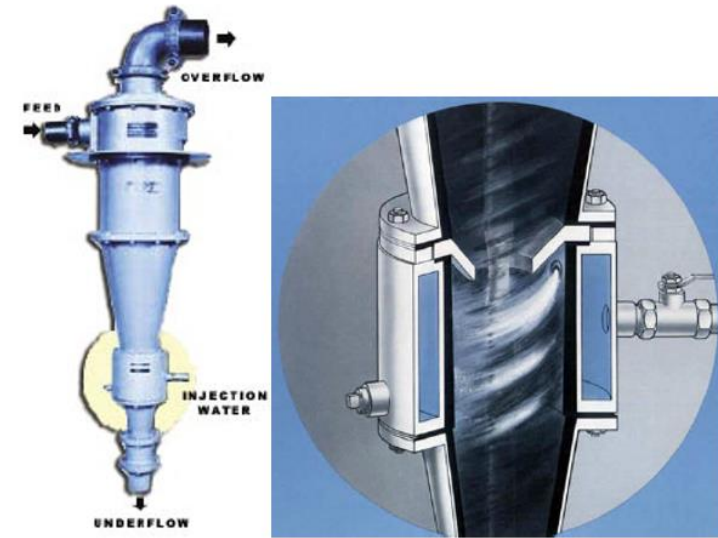
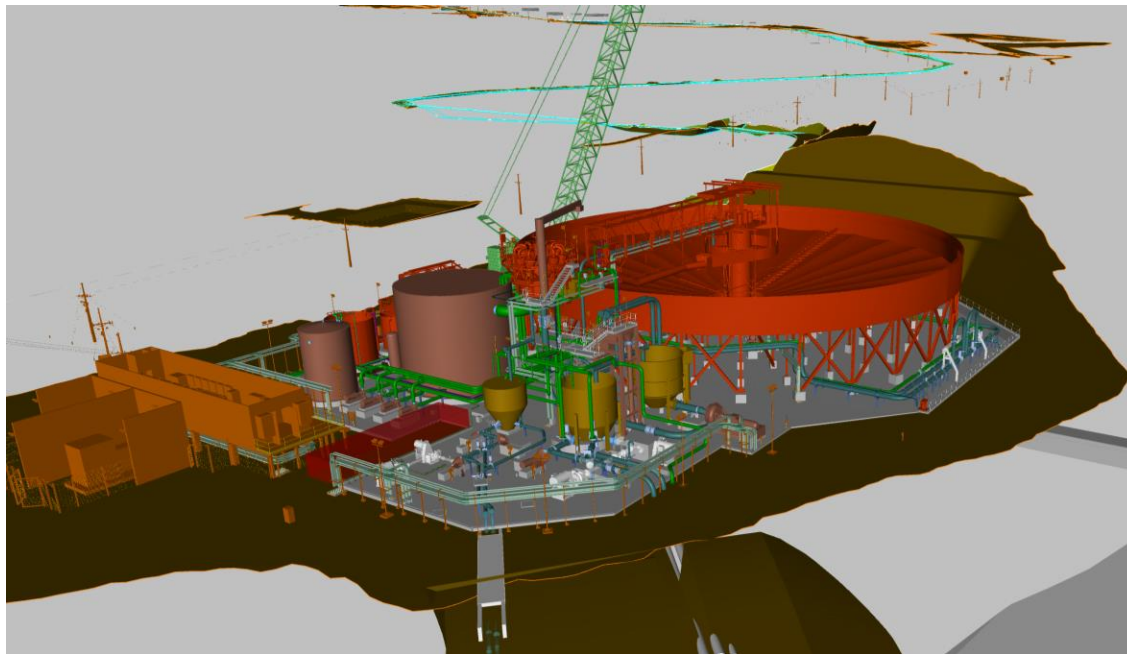

Sand Dewatering Options

- Dewatering cyclones -> stockpile
- High frequency screens
- Screen/cyclone combinations

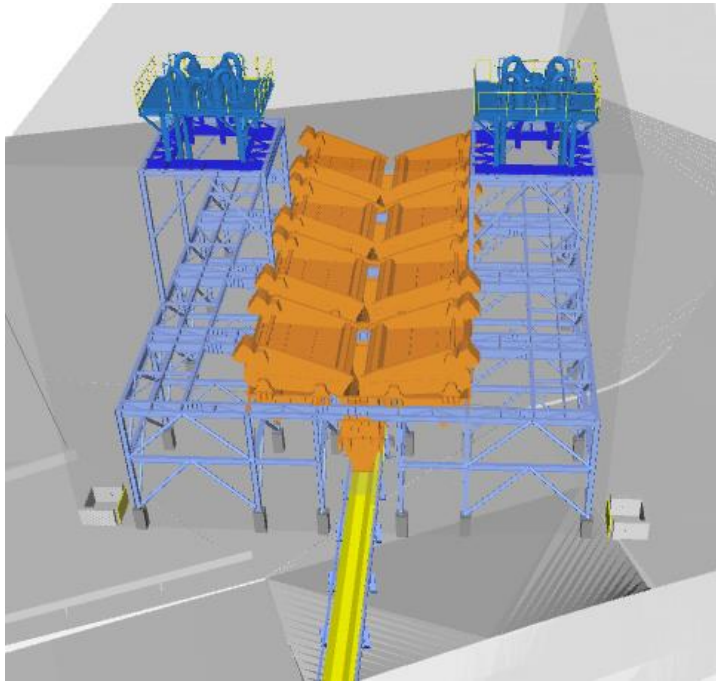

Sand Dewatering & Placement Options

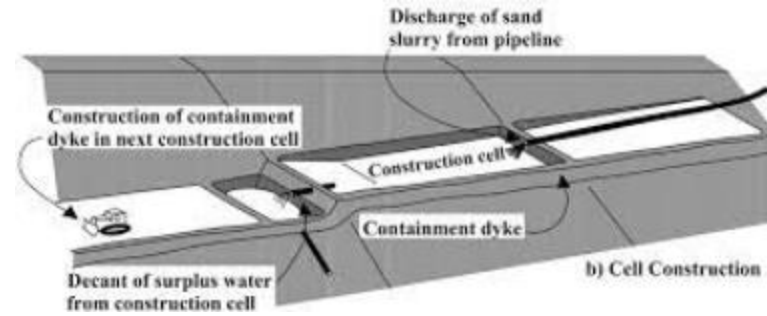
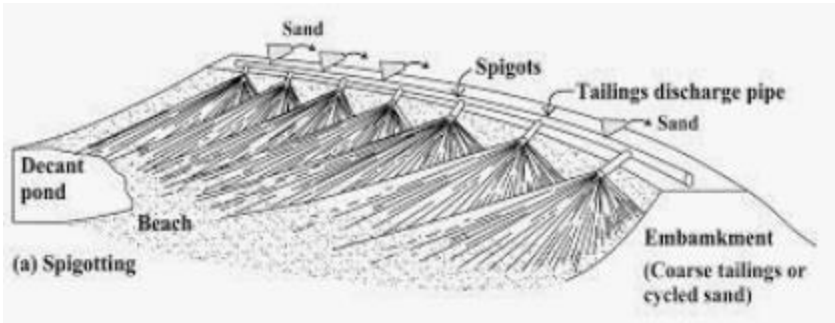

Sand Placement

- Multiple options to place coarse sand in different ways for drainage



Sand Deposition or Co-deposition with Trucks?

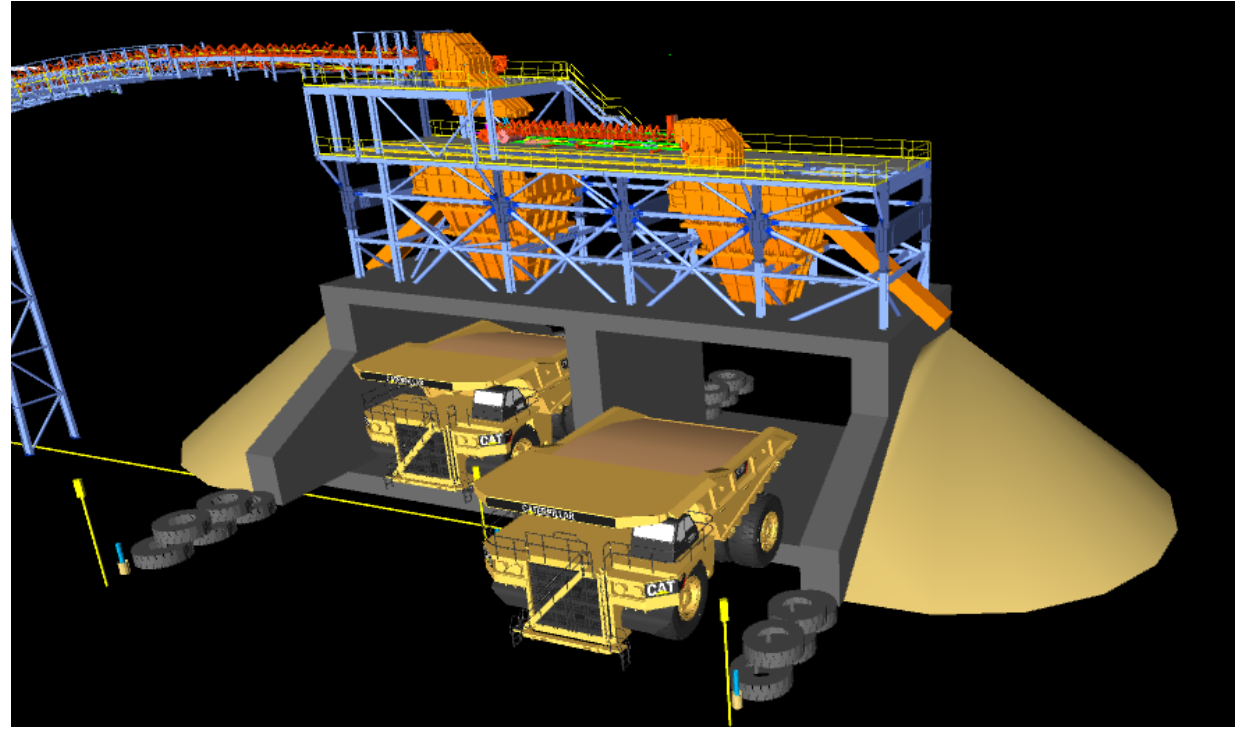
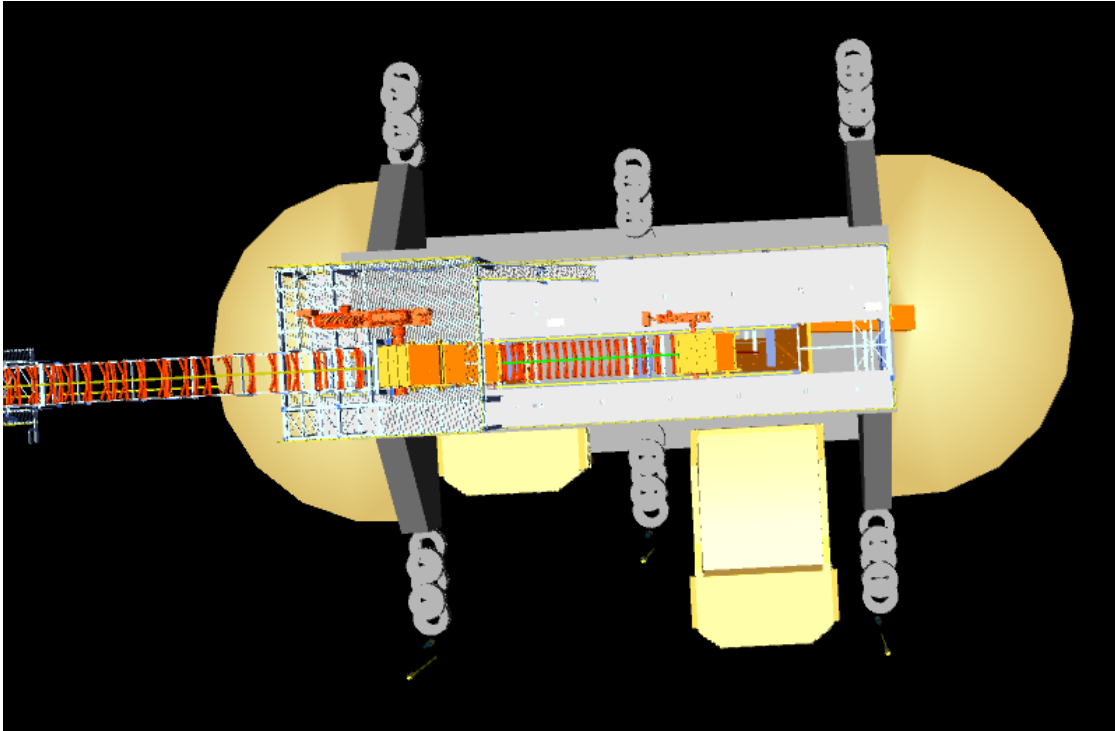

Anglo American Hydraulic Dewatered Stack Concept



Anglo American Hydraulic Dewatered Stack Concept

- TSF with an underdrain / porous base.
- Sand channels for permeable flow of water from TSF to pond/reclaim
- Sand acts as a filter medium for tailings



[Here's some serious stone slinging: 1800 tons in one shift \(focusonaggregates.com\)](https://www.focusonaggregates.com)

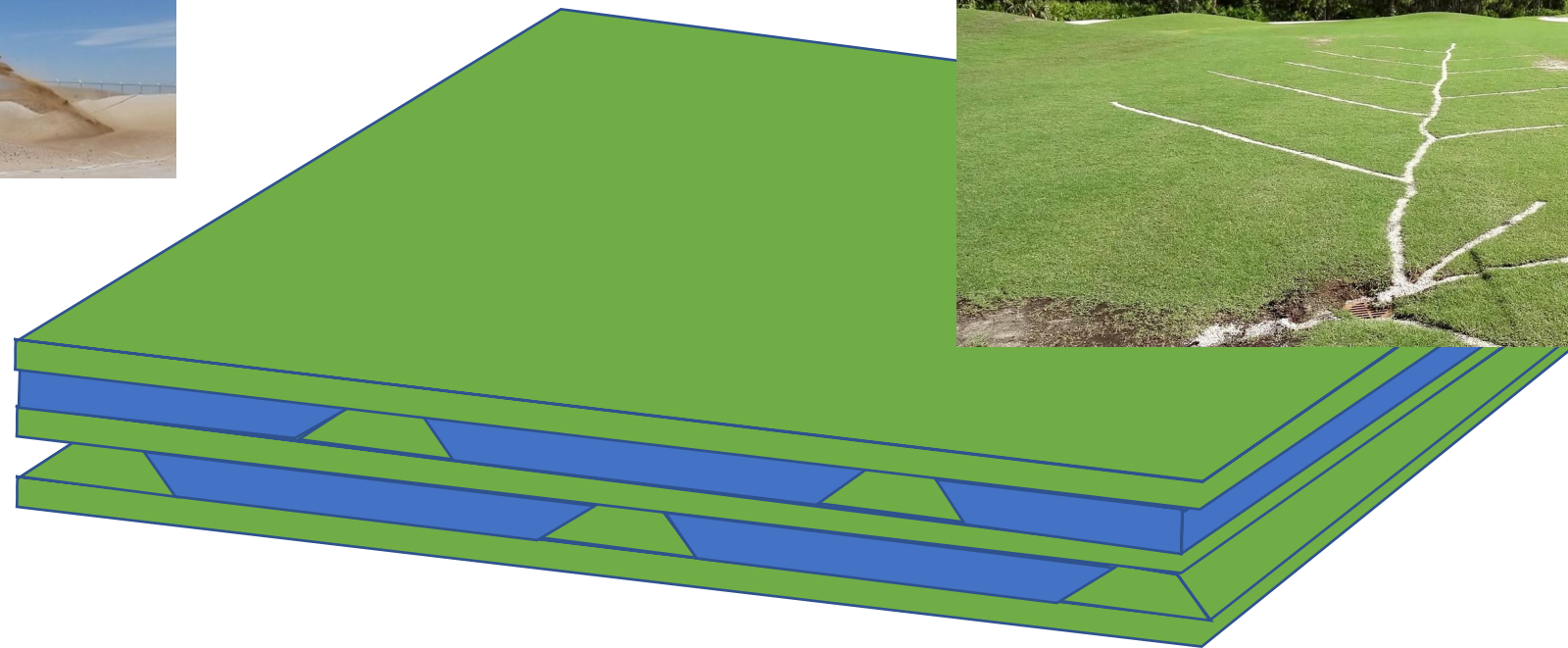

Just like dewatering the back nine



Next Generation Tailings Deposition Strategies

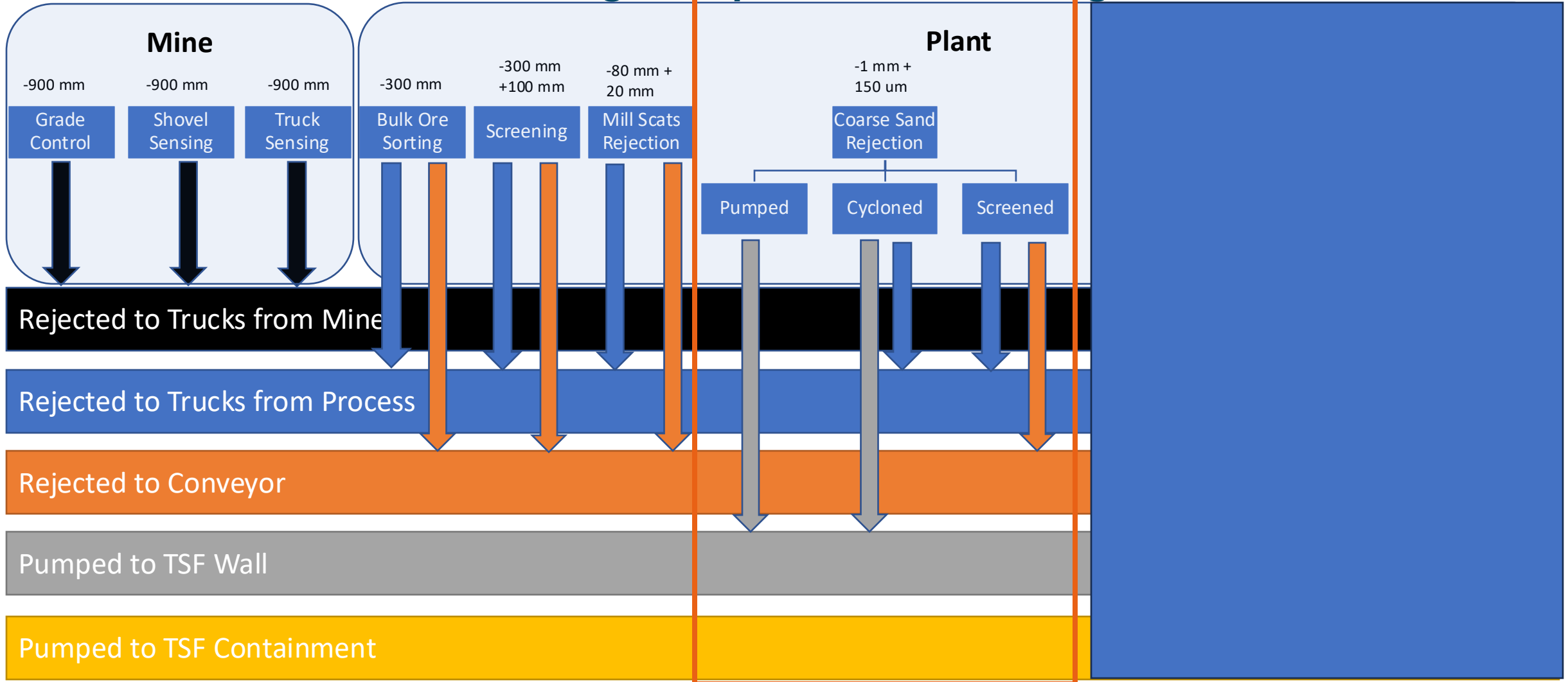

Tailings Deposition Strategies

“Conventional” waste approach:

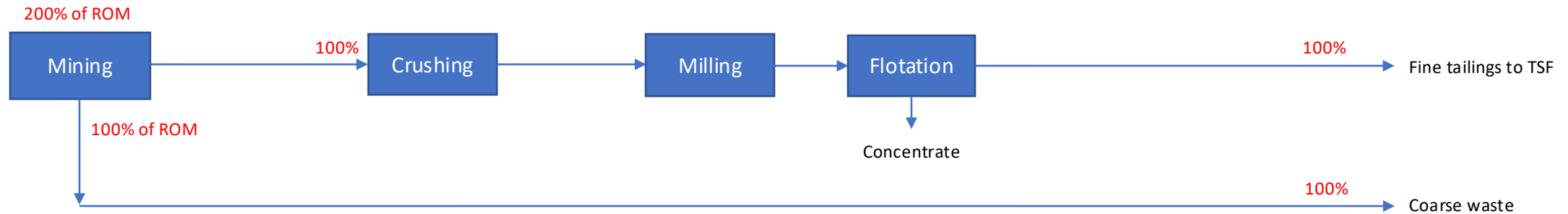

“Next Generation” waste approach, for same mining production:

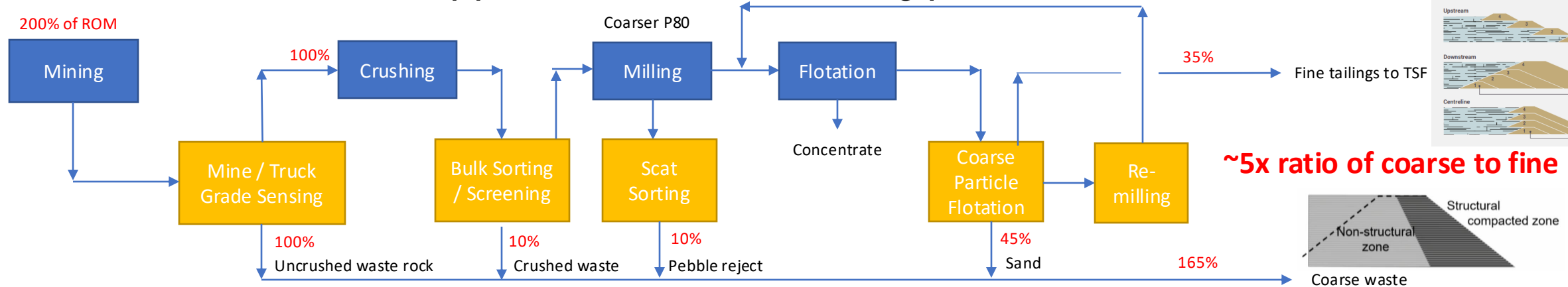

*Assuming 2:1 strip ratio



Co Disposal: Engineering stable tailings

- How do we store fines with good geotechnical properties?
- Generally speaking, void fraction is 40%
 - 2 t of sand can 'hide' 1 t of fines in voids
 - 4 t of rock can 'hide' 2 t of sand + fines
- In the right ratios, bulk density, stability, water ingress, geochemistry, dust, footprint, materials handling and stack heights all improve

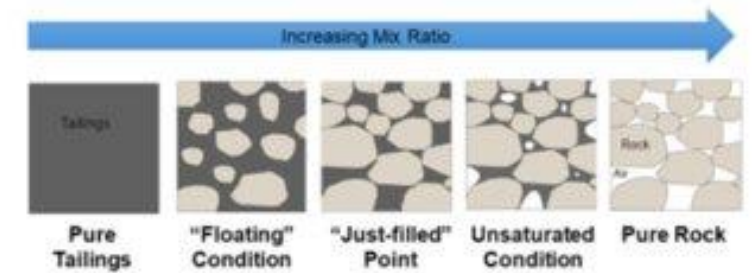
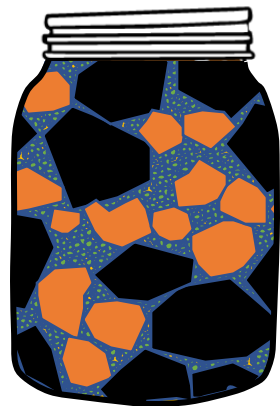
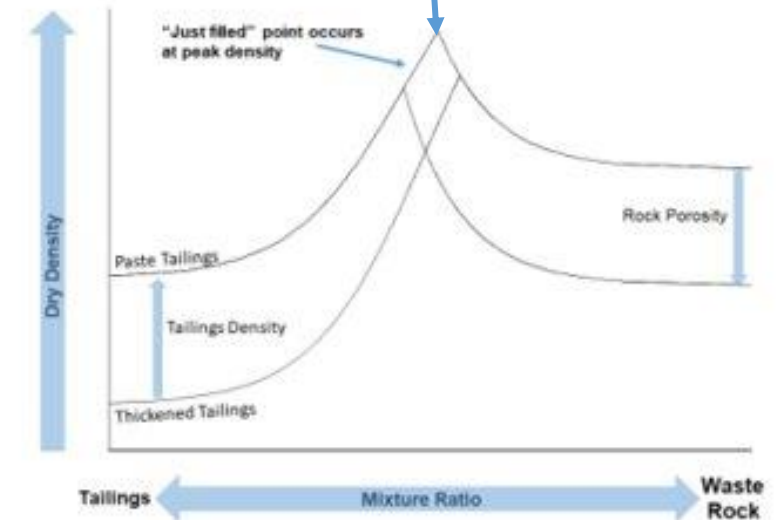

Figure 2 Blend configurations (After Wickland et al. 2006)



Co-disposal Methods

- Co-mingling
 - Tailings and coarse waste rock material transported independently
 - Mixed mechanically in storage facility or slurry-pumped
 - Mixing promotes voids filling (mingling) to maximise density
- Co-placement
 - Not mixed to form a single discharge stream
 - Waste rock end dumped into tailings facility
 - Waste rock for internal berms or retaining walls (sometimes)
- Co-deposition
 - Similar to co-placement, but waste streams placed in layers
 - Deposited tailings naturally enters voids in underlying rock
 - End-dumping waste rock with tailings deposition down face prior to further end dumping



How should we design our tailings?

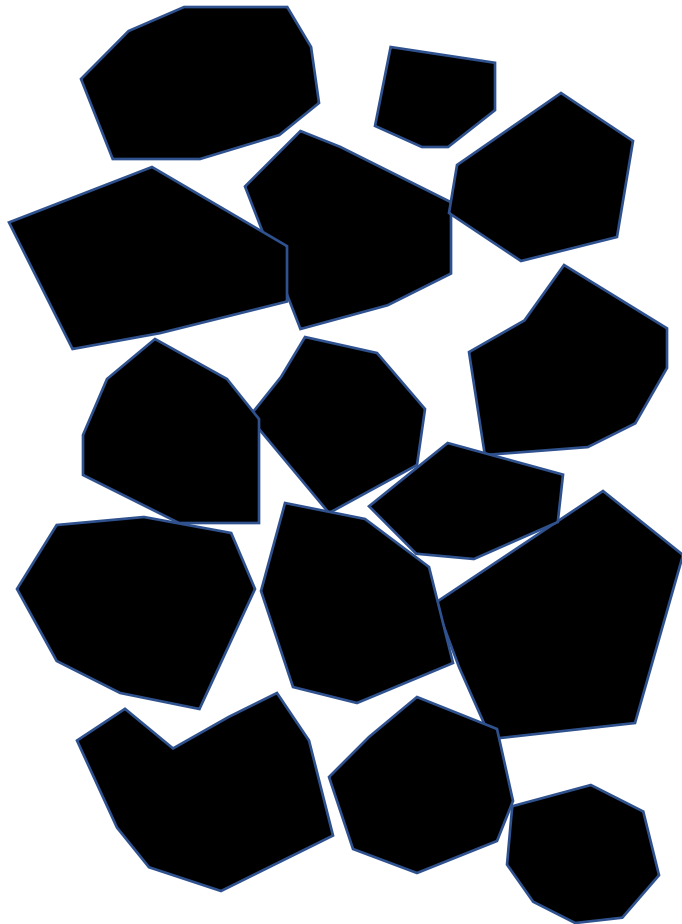

Waste Rock

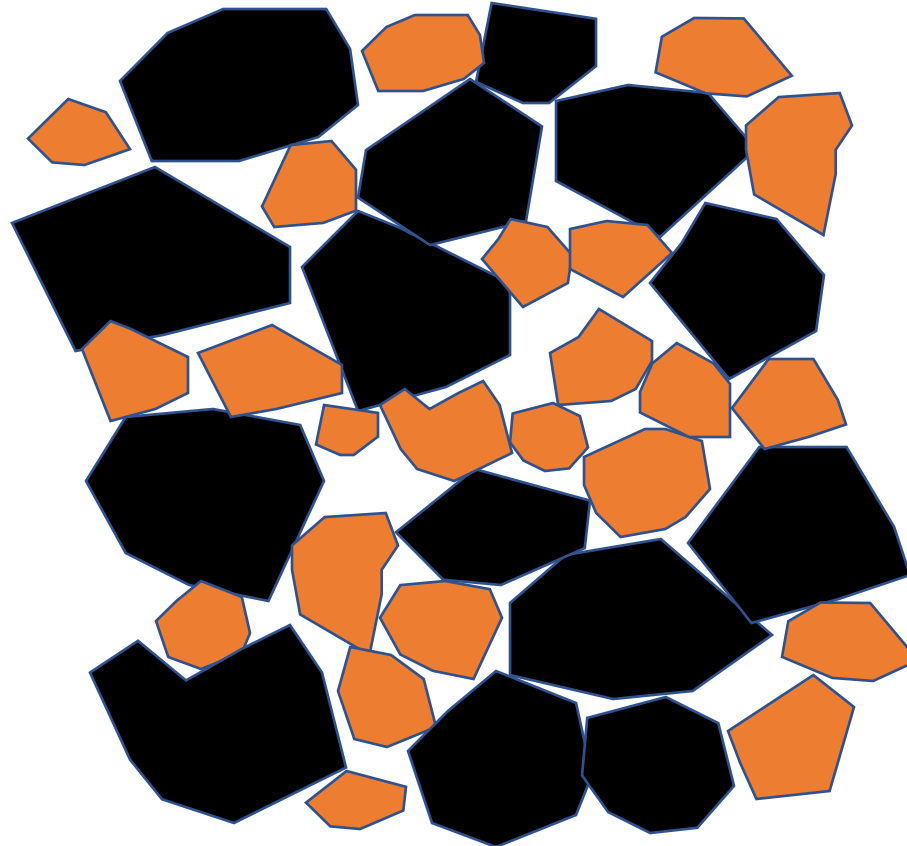

Waste Rock + Pebbles

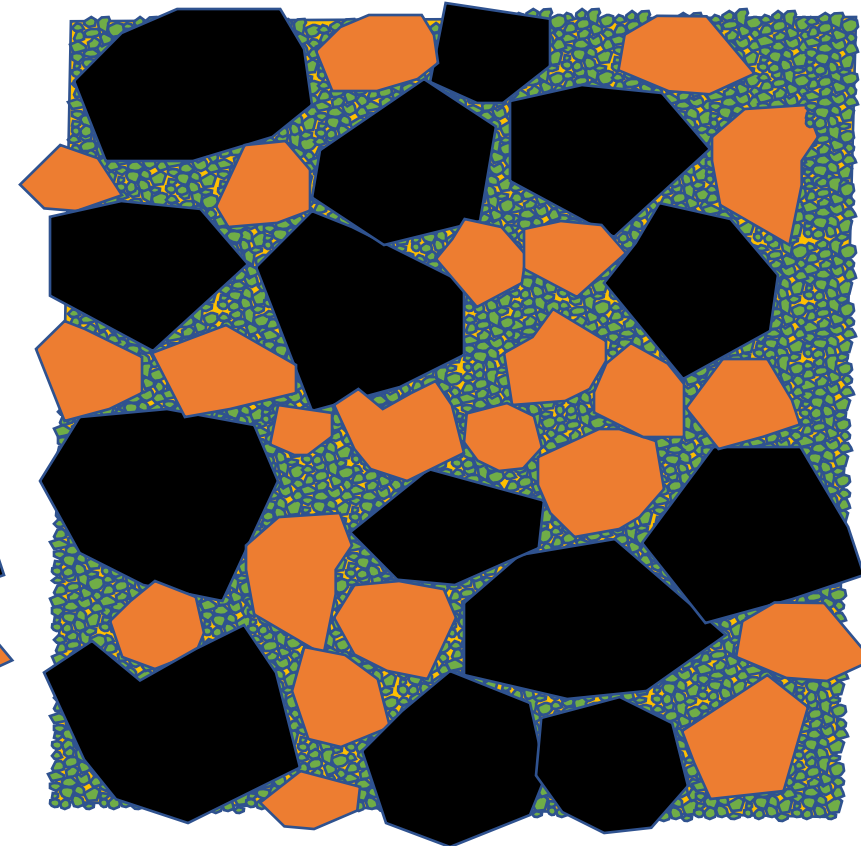

Waste Rock + Pebbles + Sand + Fines



How should we design our tailings?

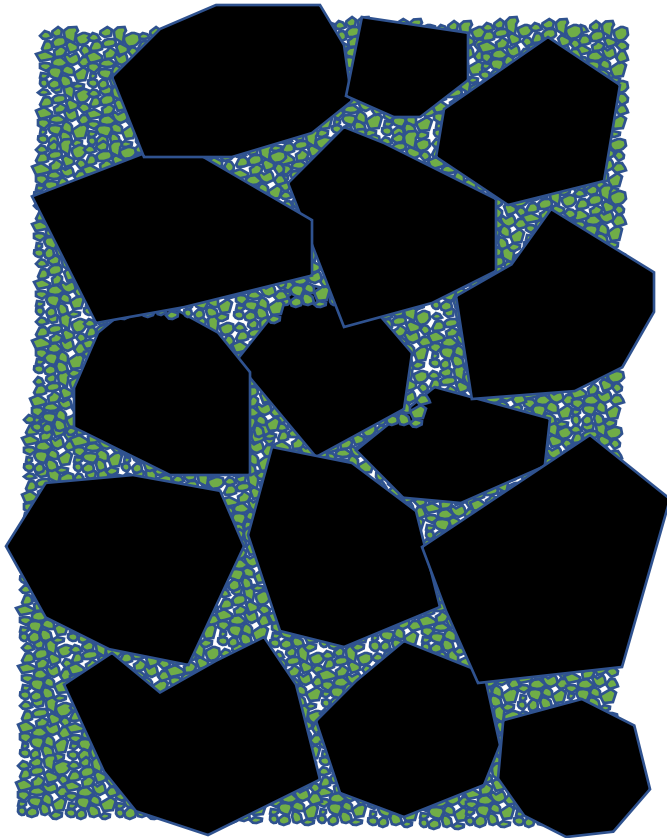

Waste Rock + Sand / Fines

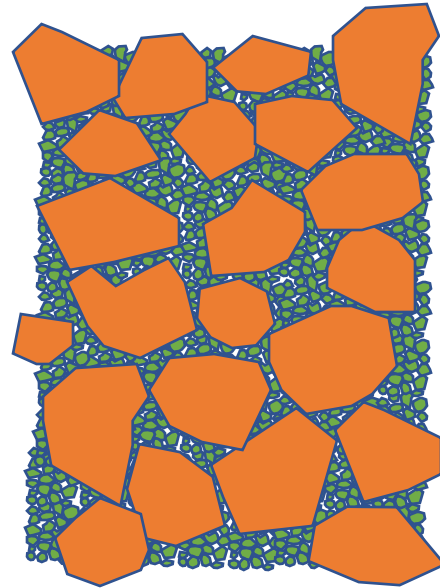

Pebbles + Sand / Fines

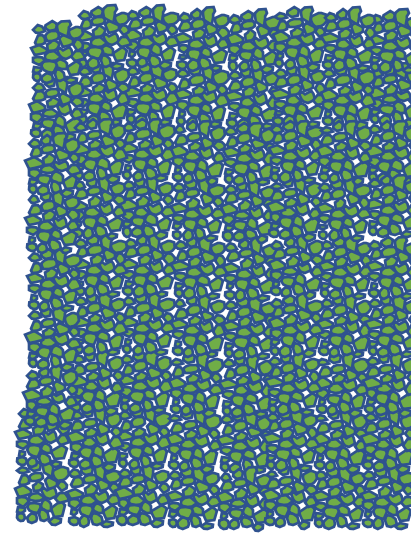

Sand + Fines

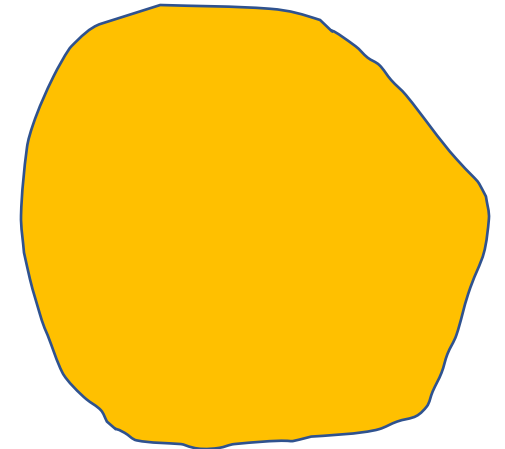

Any fines remaining that need dewatering?



Do what we already know... Or?

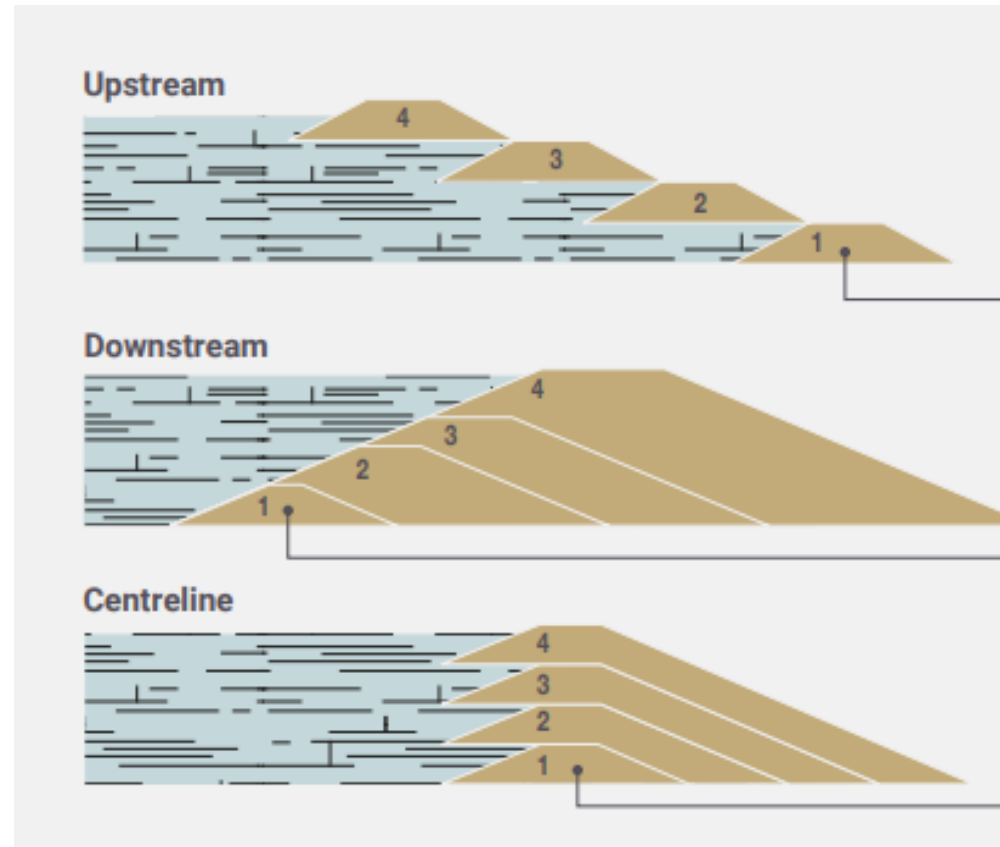

Example: 120ktpd Cu-Au Project (Canada)

2023 NI43101 TMF Facility – Baseline Case

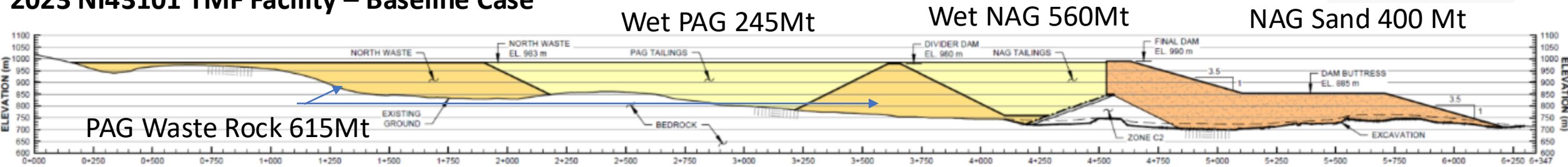

- Conventional Canadian Tailings approach in design
- Conventional valley fill tailings: ~1.8 Bt of tailings/waste over 27 year mine life.
- ICOLD Extreme category dam w/ sand embankment >300m high and significant runout volume.
- Significant permitting challenges related to tailings dam.
- No current date for project execution

What would need to be different to unlock this project?



Next Generation Tailings Deposition Strategies

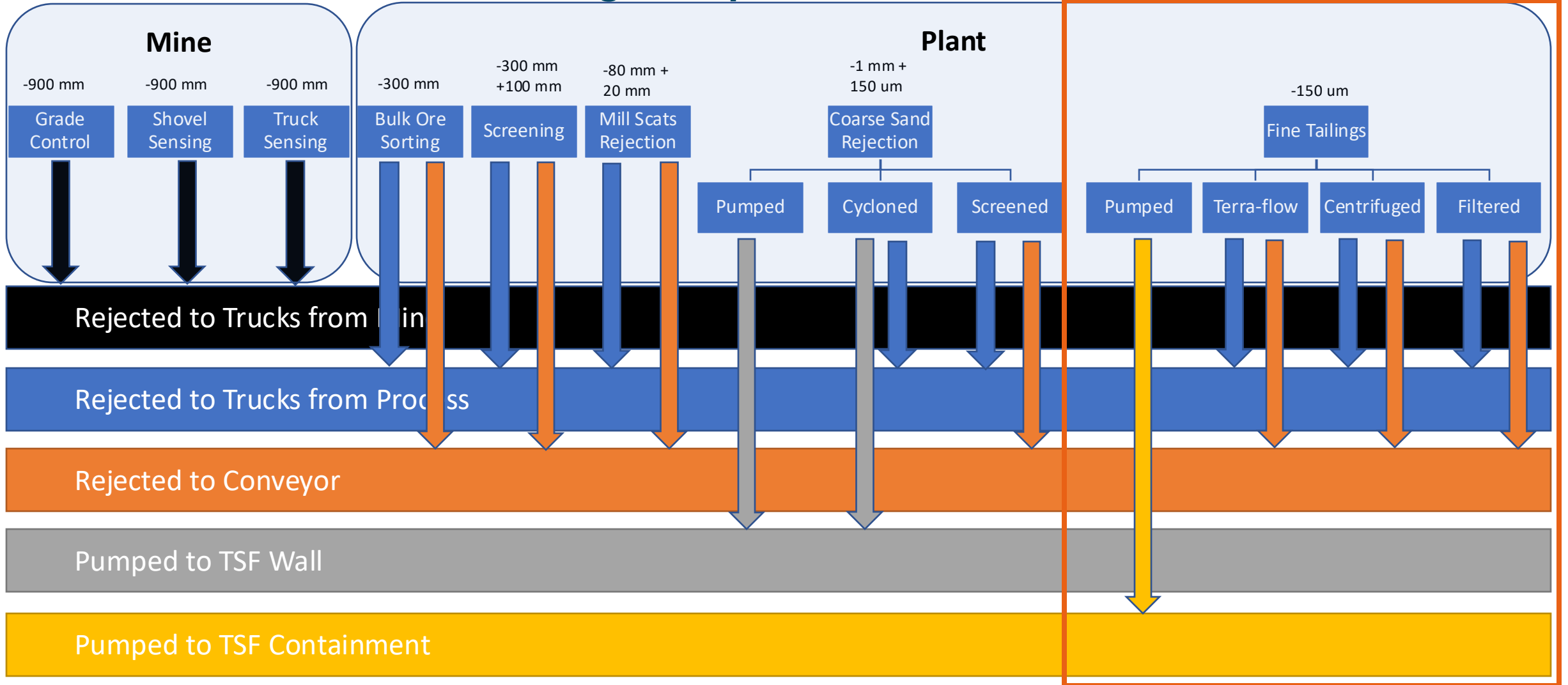

Wet - Paste Tailings Storage



4 degree beach slopes from high density paste vs 2 degree for convent



What does this mean for storage? Should we be reconsidering CTD or DVD as a 'safer' storage method?

Even 'badly thickened' CTD's can still work. Imagine what would be possible with proper density management? What can we learn / apply from underground paste plant design and constant density pumping systems?

Shrinking embankment requirements

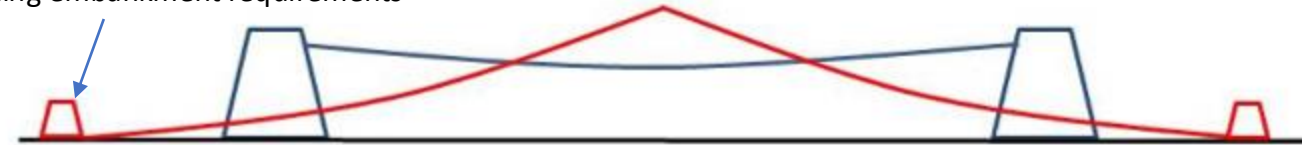

Figure 3 A CTD (red) and a conventional tailings ring dyke (blue) of similar capacity



Wet -centrifuged fine gold tailings – somewhere between pumpable and conveyable yet flowable!!!



Terraflow | Weir

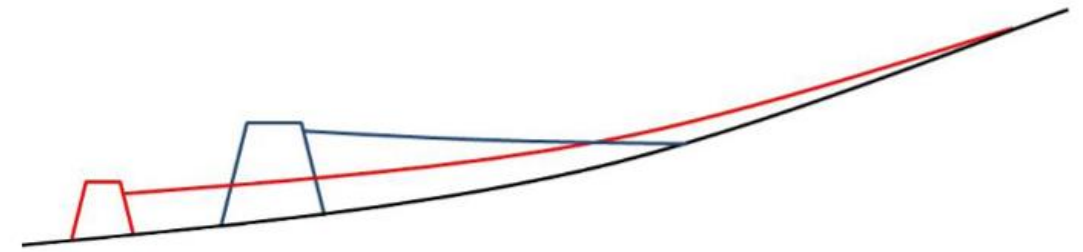
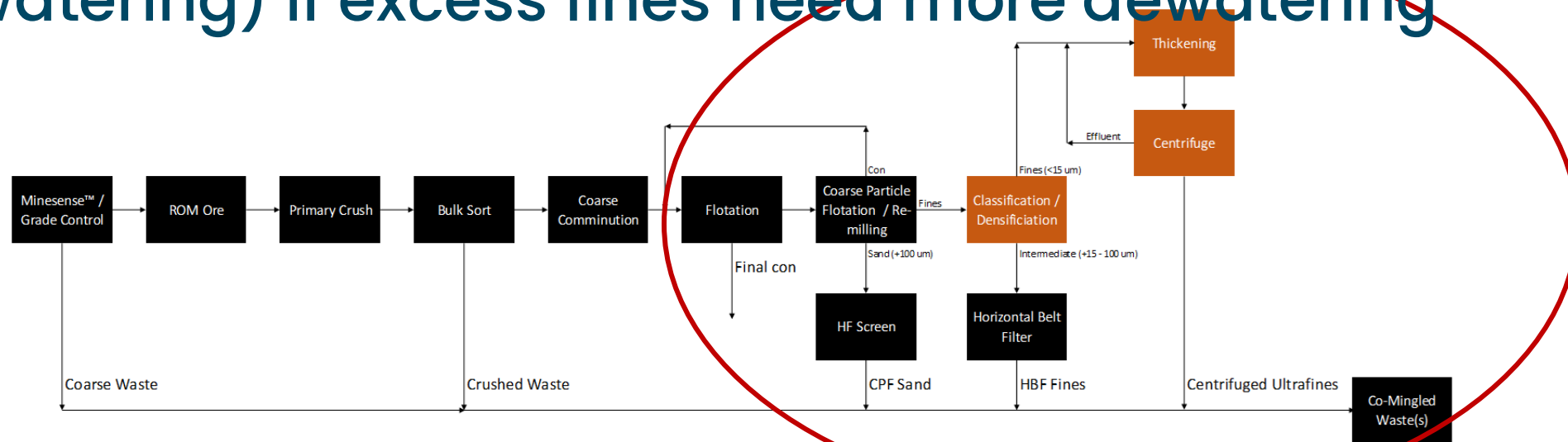

Figure 4 A DVD (red) and a conventional valley dam (blue) of similar capacity

Significant savings in TSF costs possible from CTD or DVD... if only we could thicken tailings properly....



Consider centrifuges or belt press filters (chemical dewatering) if excess fines need more dewatering



	Pressure Filters	Combination HF + HBF + CF	Comments
Moisture (% w/w)	15.5	16	Similar moisture
CAPEX (USD M)	200	90	Capex is halved or less
OPEX (USD M/y)	100	56	Opex is about half – subject to flocculant consumption

Assumes approximately half of the material is available in a 'sand' fraction (+100 um)



Example: 120ktpd Cu-Au Project (Canada)

2023 NI43101 TMF Facility – Baseline Case

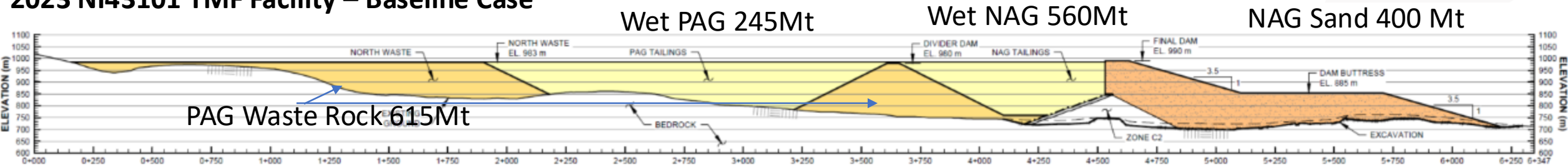

Alternative Facility

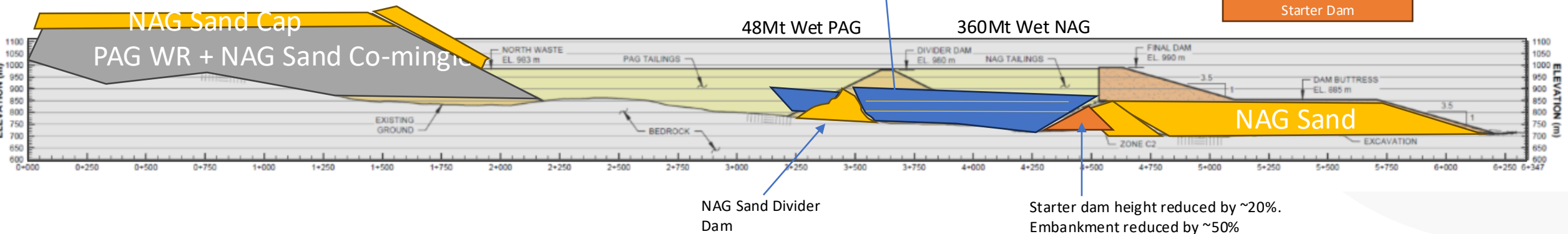

Pick and choose to mix the right streams together, optimising dewatering and placement costs

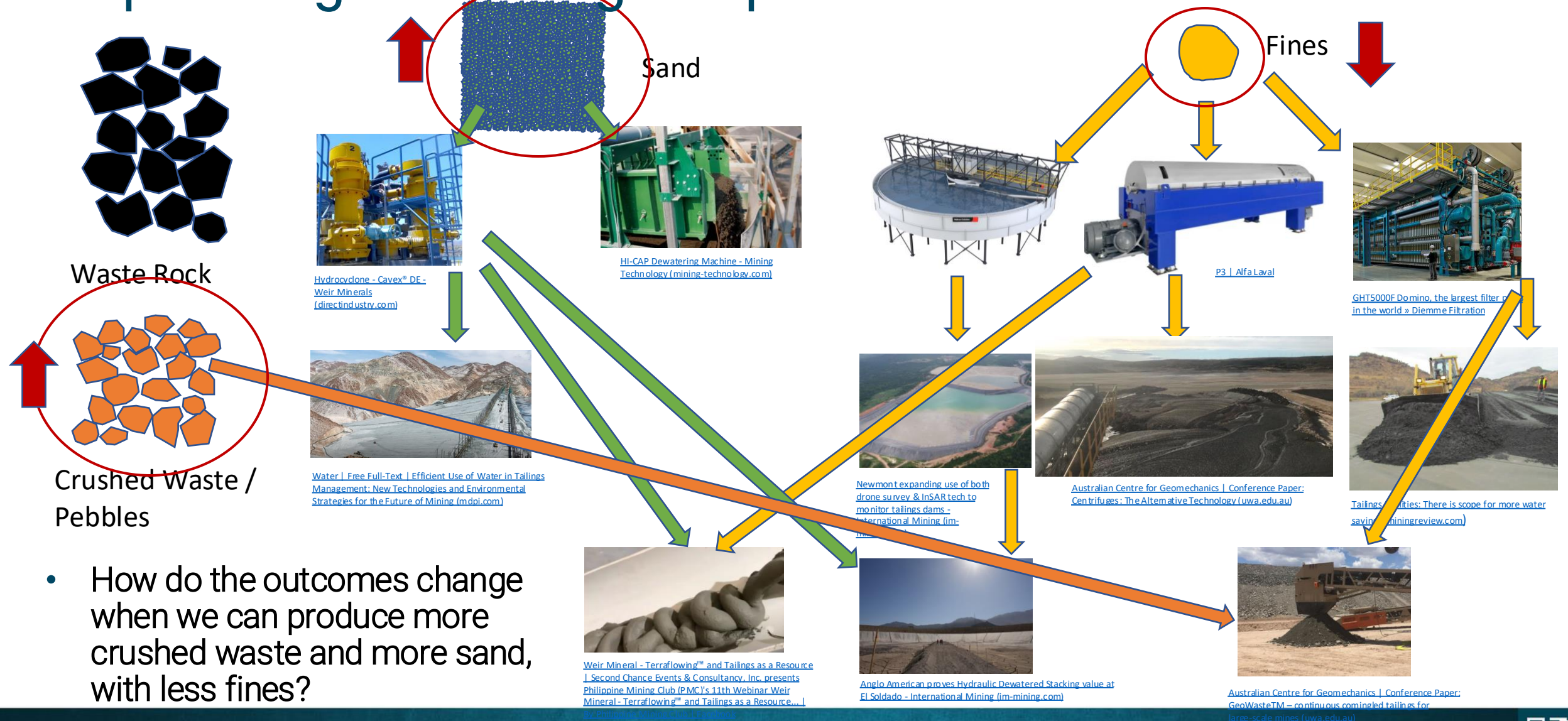

- How do the outcomes change when we can produce more crushed waste and more sand, with less fines?



Tailings Deposition Strategies

“Conventional” waste approach:

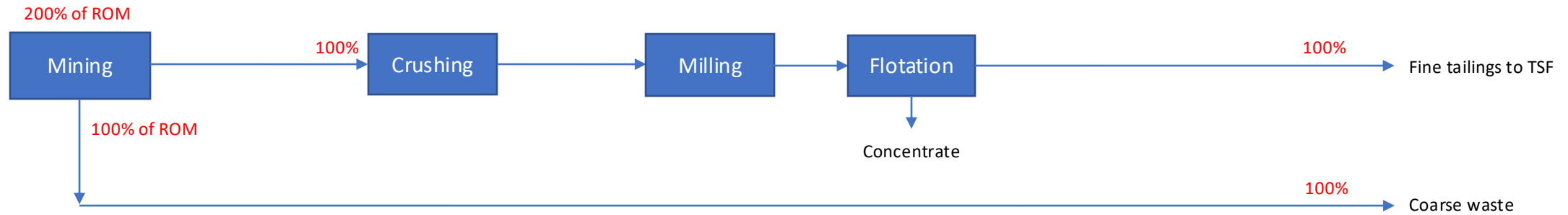

“Next Generation” waste approach, for same mining production: **>80% reduction in wet TSF tailings**

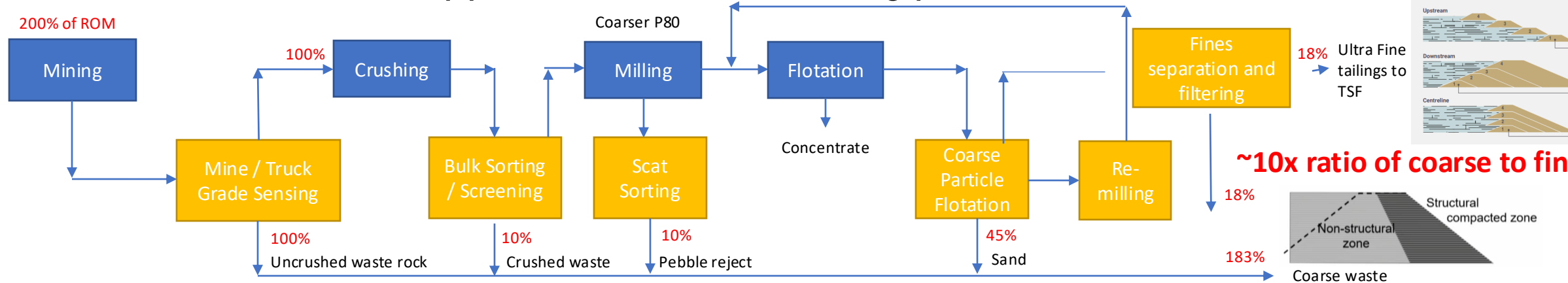

*Assuming 2:1 strip ratio



6

Closure,
landforms

Campbell
Haynes



Closure burden

- 50% of active tailings dams built in the last 10 years. Growing cost burden for companies / governments in perpetuity.
- 8 Billion tonnes placed in 2016 alone.
- How does tailings methodology impact closure costs?
 - ARD
 - Stability
 - Capping and regeneration

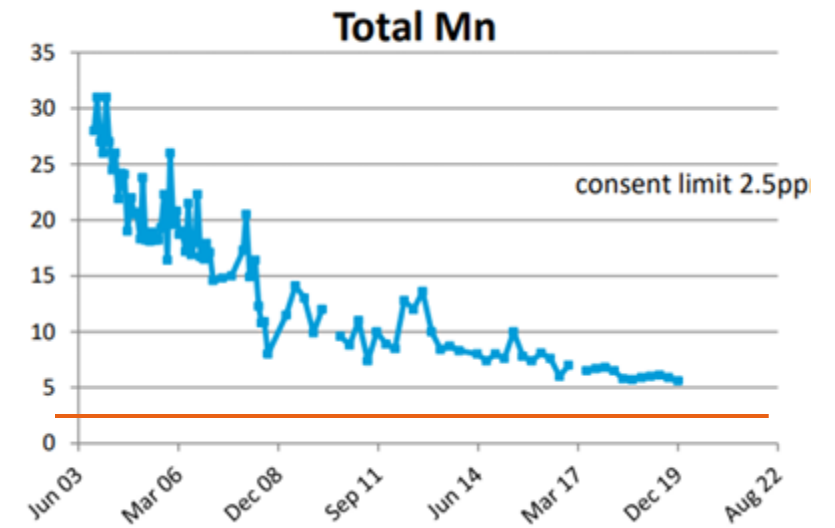
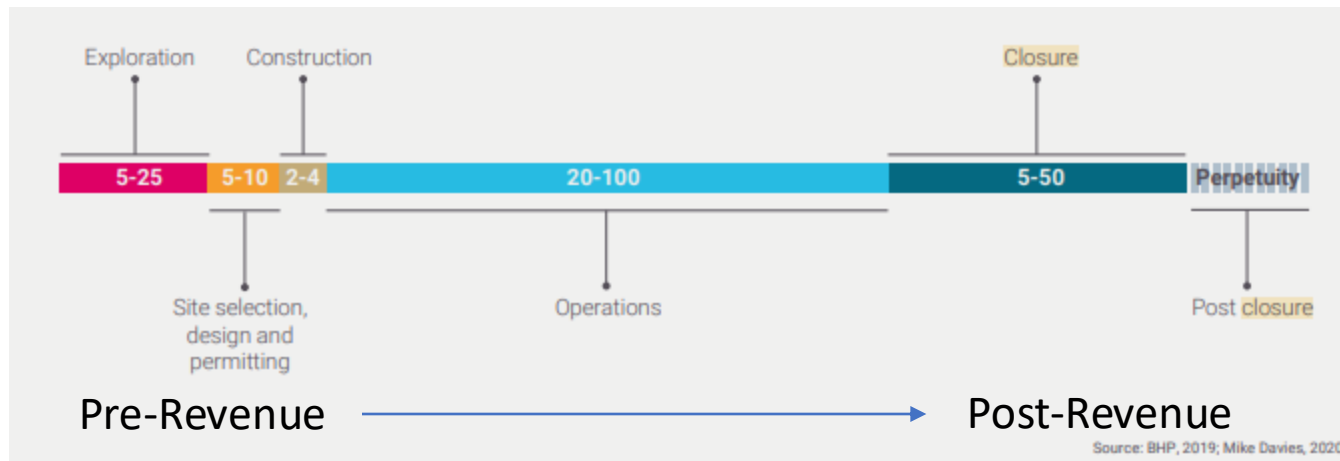

[Case-Study-Golden-Cross.pdf](#)

'Instability in the tailings storage facility (TSF) required mine closure to manage the issue, with abundant resources left in the ground.'



Closure Cost and Complexity

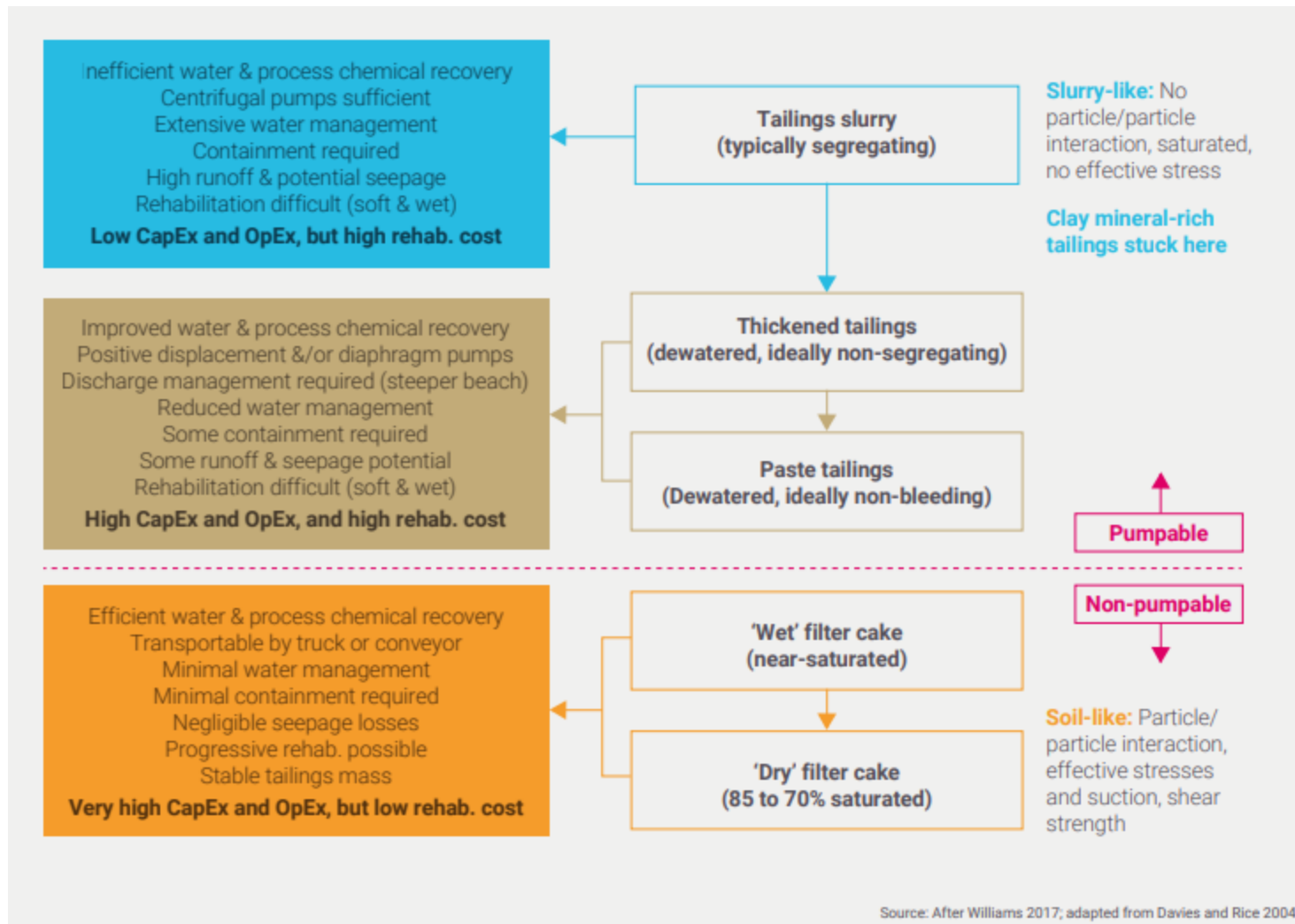

Hard and Expensive

Decreasing Cost and Complexity. Reducing long term liabilities

Simpler and faster



Closure Capping

Highly dependent on project climate factors and tailings dewatering/placement methods

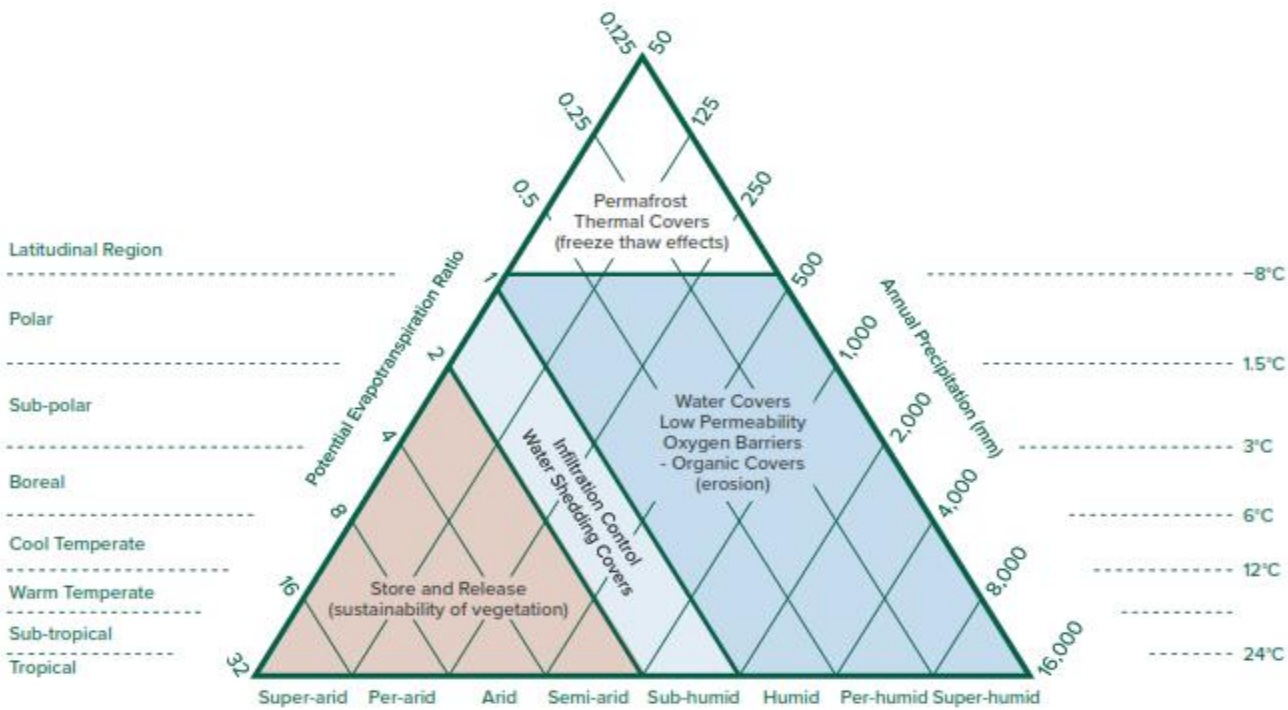
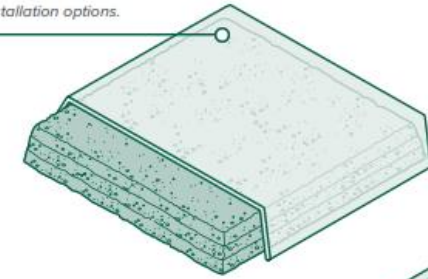

Figure 5: Permanent engineered cover installation options.

Post operation closure cover.

The tailings are stacked in layers across the entire footprint for life of operation. The permanent closure cover is then constructed after tailings placement ceases.



Progressive closure cover.

The tailings are stacked on a portion of the footprint and the permanent closure cover is progressively constructed as each stage reaches its final stack height.

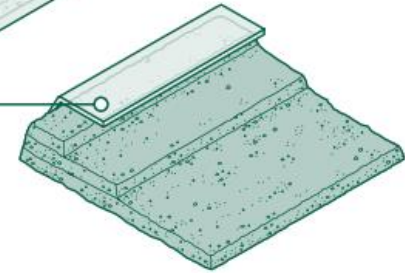

Progressive closure capping not possible with wet dams

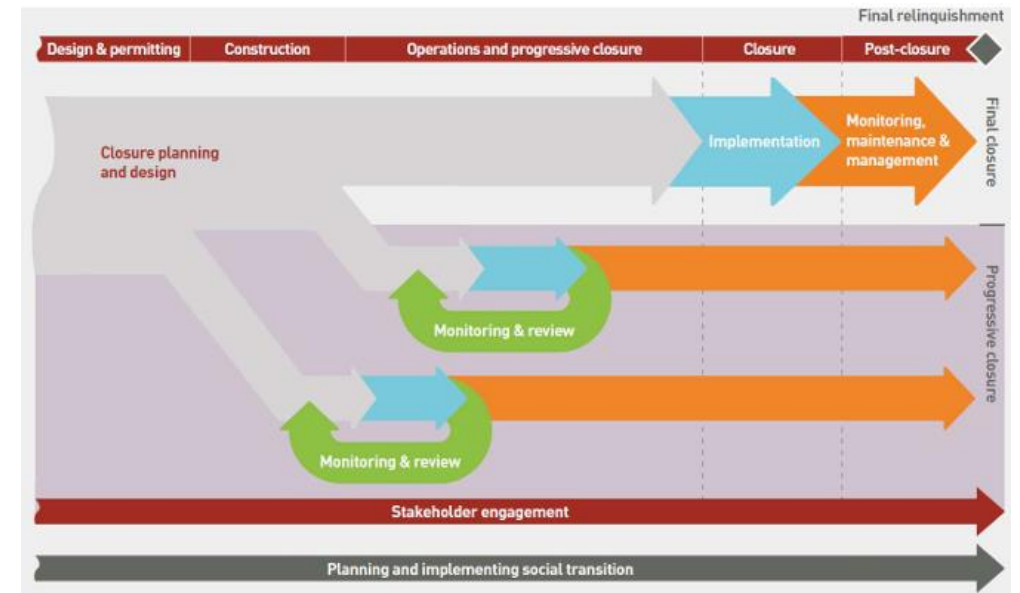

Chapter 6, www.gardguide.com



Designer Tailings Closure Benefits

- Smaller land forms (simpler permitting, lower rehab cost (Wisdom et al, 2018))
- Reduced air / moisture ingress, reducing ARD potential (Wickland et al, 2006)
- Progressive closure possible
- Minimised Wet tailings volumes to manage

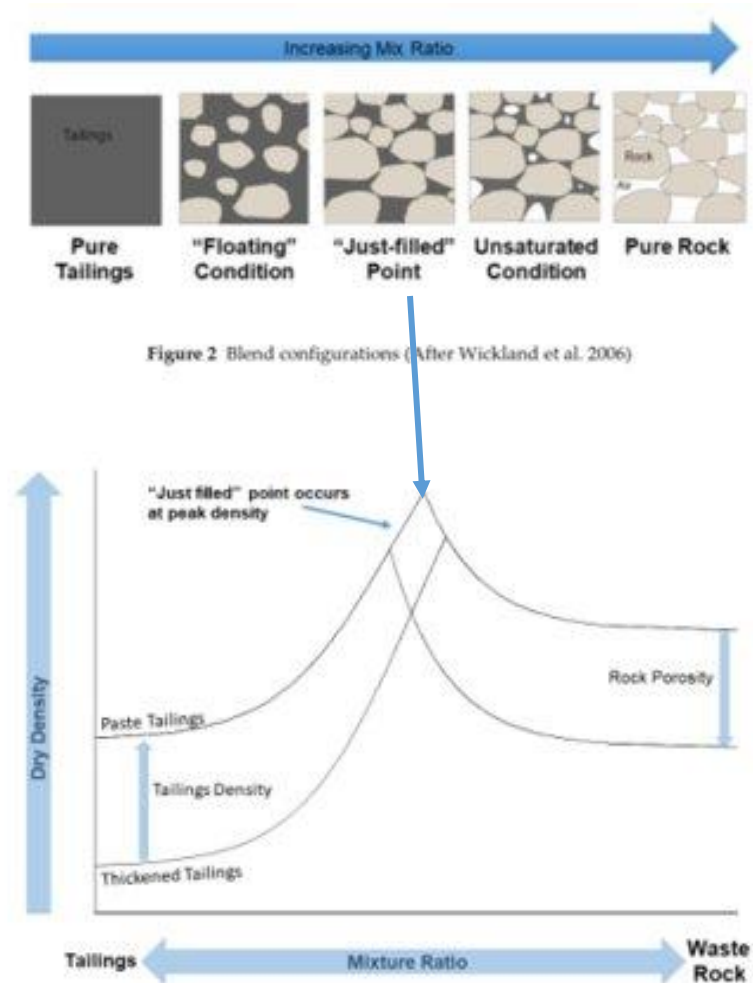
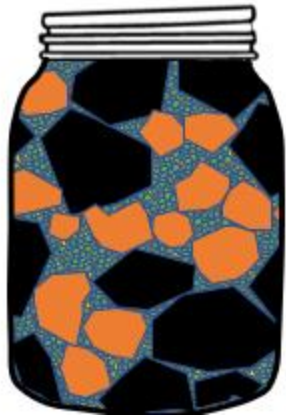

5

Conclusions

Are there any other ideas that you have seen tested which was not covered today that you can discuss/share?

What don't we know that we need to know or investigate for these types of solutions to be considered by industry?



Call to Action & Feedback – where next?



Participate

- CEEC-hosted Focus Group (COP)
- Panel Discussion (this Wednesday)
- CEEC-hosted LinkedIn forum

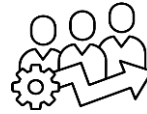

Feedback

- Workshop Process
- Post-Workshop White Paper
- Open and candid exchange of views and experience
- Peer Review of Findings



Contribute

- Post-workshop examples
- Research Seeding
- Knowledge Collaboration



Thanks!!

Premier



Corporate



*Thanks go to
Sponsors, my co-
host, the Technical
Speakers and you
the Participants.*

Celebrate. Collaborate. Communicate.

